



Pumps



***CPX***  
***ISO Chemical***  
***Process Pumps***

- CPX***
- CPXS***
- CPXM***
- CPXP***
- CPXR***
- CPXV***

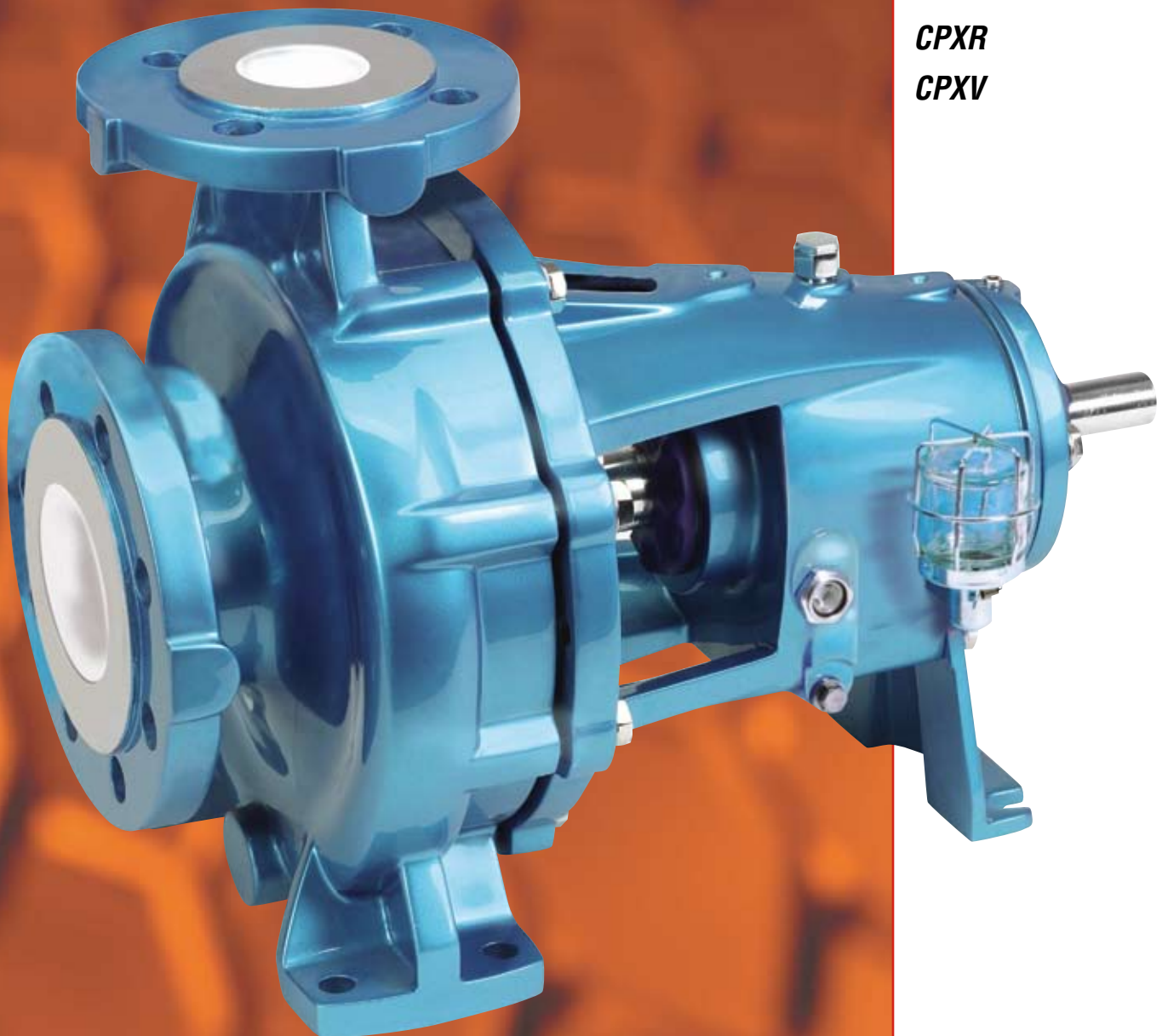

## Pump Supplier To The World

*Flowserve is the driving force in the global industrial pump marketplace. No other pump company in the world has the depth or breadth of expertise in the successful application of pre-engineered, engineered and special purpose pumps and systems.*

### Pumping Solutions

Flowserve is providing pumping solutions which permit customers to continuously improve productivity, profitability and pumping system reliability.

### Market Focused Customer Support

Product and industry specialists develop effective proposals and solutions directed toward market and customer preferences. They offer technical advice and assistance throughout each stage of the product life cycle, beginning with the inquiry.



### Dynamic Technologies

Flowserve is without peer in the development and application of pump technology, including:

- Hydraulic engineering
- Mechanical design
- Materials science
- Intelligent pumping
- Manufacturing technology

### Broad Product Lines

Flowserve offers a wide range of complementary pump types, from pre-engineered process pumps, to highly engineered and special purpose pumps and systems. Pumps are built to recognized global standards and customer specifications. Pump designs include:

- Single stage process
- Between bearing single stage
- Between bearing multistage
- Vertical
- Submersible motor
- Rotary
- Reciprocating
- Nuclear
- Specialty

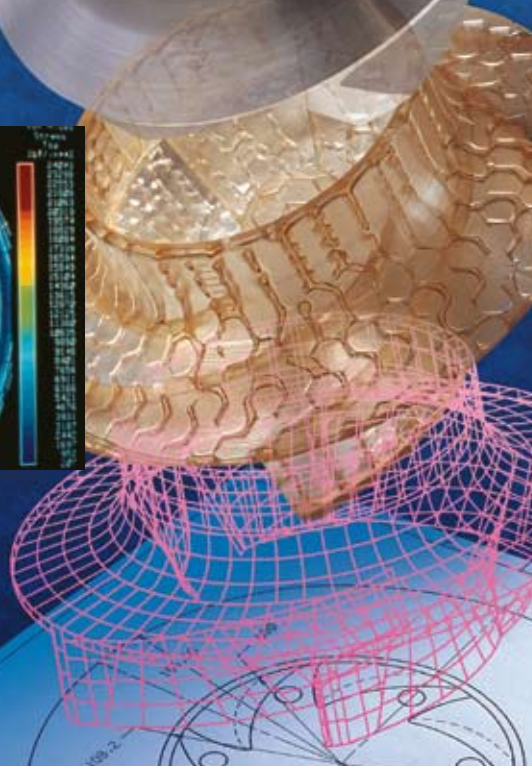
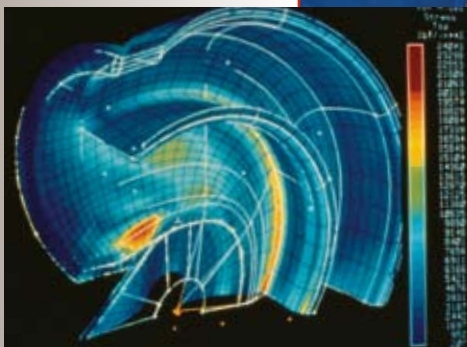

## CPX Family of ISO Chemical Process Pumps

### Unmatched Versatility and Flexibility

The CPX family of ISO chemical process pumps offers a wide range of configurations including mechanically sealed, magnetically driven, self-priming, close coupled and vertical pumps. The CPX family, therefore, offers unmatched flexibility and breadth of pumping solutions in countless applications.

### Spare Parts Interchangeability

Commonality among the different pump configurations is a key benefit of the CPX family. All CPX pumps share the same state-of-the-art hydraulics, sealing options, and bearing frame options. This interchangeability translates into inventory and maintenance costs savings.

### Industries

- Chemical
- Steel and primary metals
- Marine
- Wastewater treatment
- Aquariums
- Mining works
- Semiconductor manufacturing
- Pharmaceuticals
- Petrochemical

### Complementary Pump Designs

- Mark 3 ASME (ANSI) chemical process pump
- PolyChem PFA lined series of sealed or sealless ISO, ASME (ANSI) or JIS pumps
- GRP ASME (ANSI) non-metallic chemical process pump

### Table of Contents

#### CPX ISO Standard Pump

CPX Standard.....	4-5
Performance Curves ...	10
Interchangeability.....	11
PROS+ System.....	11

#### Features and Enhancements

Seal Chambers.....	6
Mechanical Seals .....	7
Shaft Design.....	8
Bearings .....	8
Parts and Materials .....	9
Baseplates.....	22-23

#### CPXS

Magnetic Drive Pump .....	12-13
CPXSM.....	13, 15

#### CPXM

Close Coupled Pump .....	14-15
--------------------------	-------

#### CPXP

Self-Priming Pump .....	16-17
CPXPM.....	15, 17
CPXPS.....	17
CPXPSM.....	17

#### CPXR

Recessed Impeller Pump .....	18-19
CPXRV .....	19
CPXRM.....	15, 19

#### CPXV

Vertical Sump Pump .....	20-21
--------------------------	-------

#### Complementary Pumps and General Information

Non-Metallic Pumps.....	24
ASME (ANSI) Pumps ..	25
ASME (ANSI) In-Line Pumps.....	25
Engineered Pumps .....	26
Global Service and Support .....	27

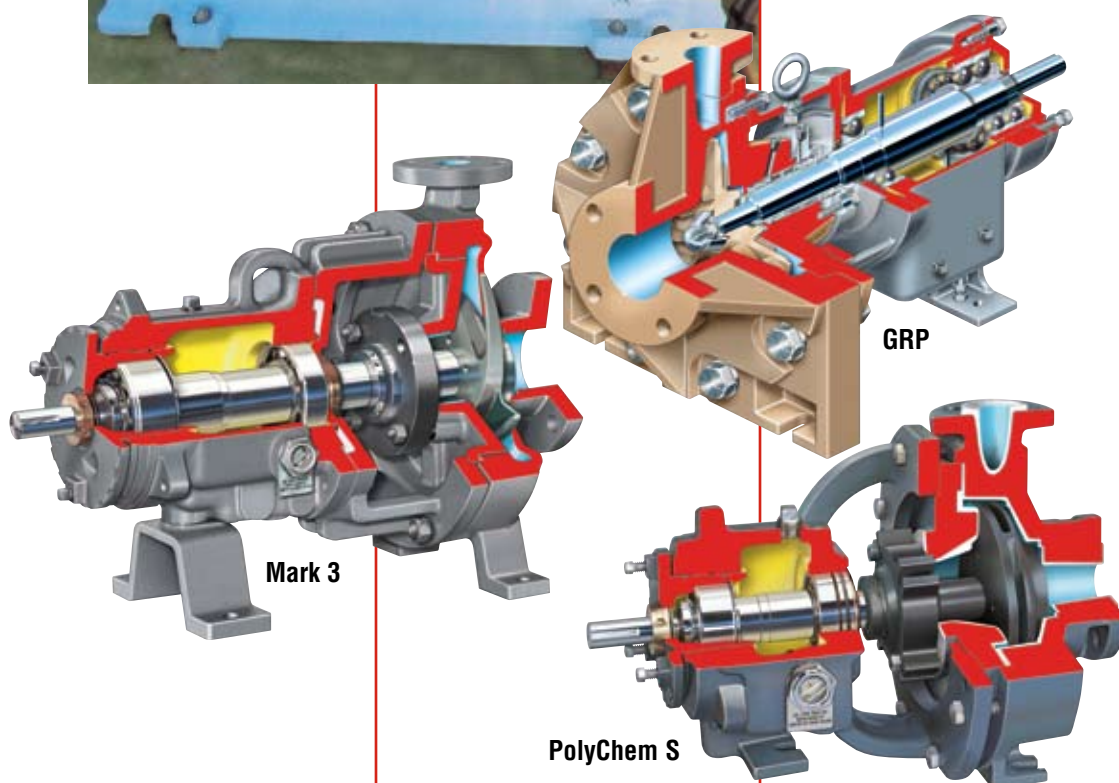

**CPX  
ISO Standard  
Overhung,  
Single Stage  
Chemical Process  
Pump**

**The Standard for Chemical Processing**

The Flowserve CPX process pump conforms to ISO 2858 dimensional and ISO 5199 design criteria. Offering state-of-the-art hydraulics, the CPX pump is designed for applications where high performance, high efficiency and low NPSH are required.

The advanced design and precision manufacture of the rugged CPX provide significant performance enhancing benefits that help users to maximize mean time between planned maintenance (MTBPM) and to reduce operating costs.

**Applications**

- Acid transfer
- Caustic and chlor-alkali
- Man-made fibers
- Polymers
- Slurry processing
- Solvents
- Volatile organic compounds
- Waste processing

**Operating Parameters**

- Flows to 1400 m<sup>3</sup>/h (6160 US gpm)
- Heads to 220 m (720 ft)
- Pressures to 25 bar (365 psi)
- Temperatures from -80°C (-110°F) to 350°C (660°F)
- Discharge sizes from 20 mm (3/4 in) to 200 mm (8 in)

**Standards Compliance**

The CPX is CE marked and compliant with applicable European directives, such as ATEX.

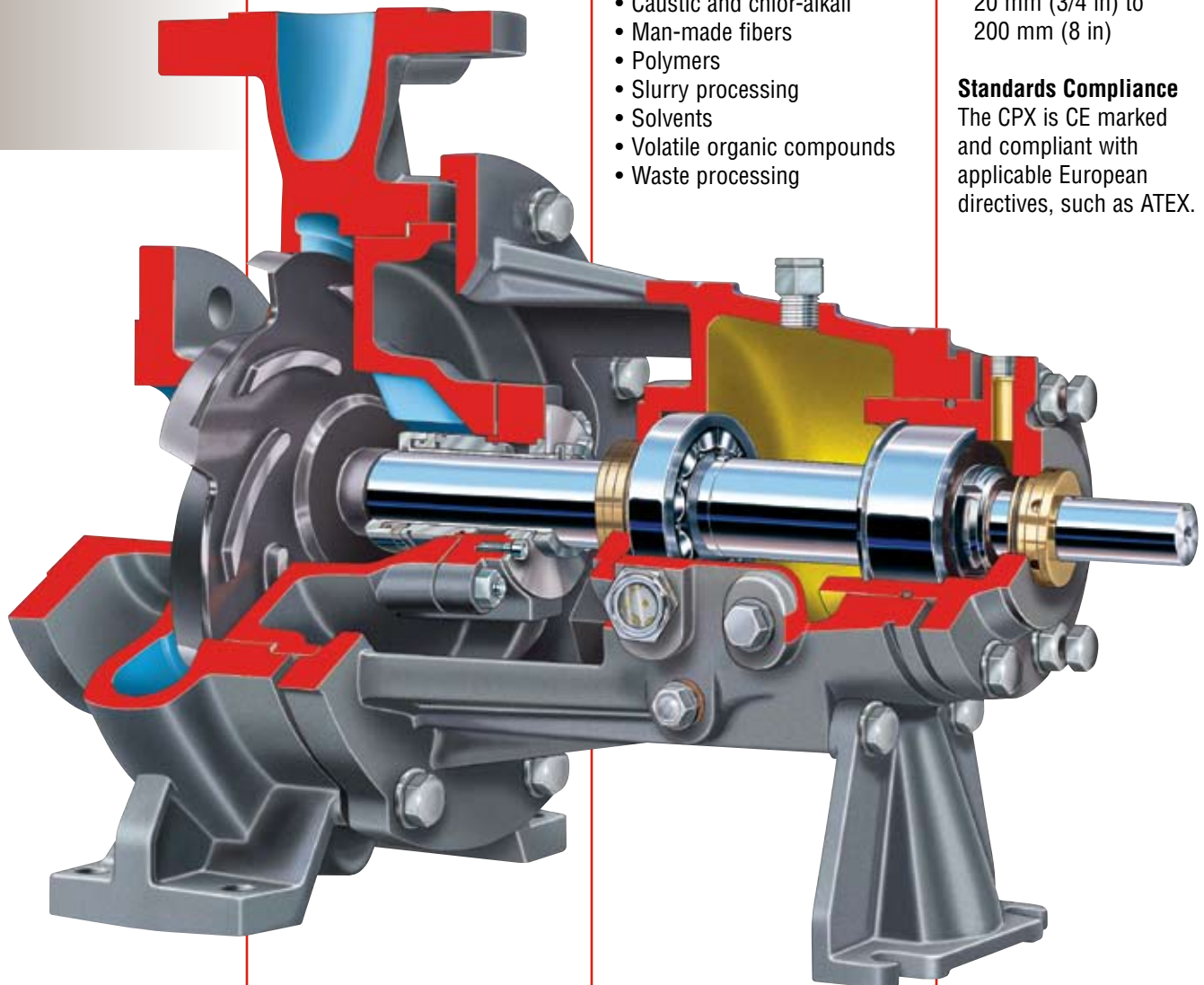

**Advanced 45° Conical Seal Chamber** with integral vortex flow modifiers increases mechanical seal life

**Standard Non-Contacting Labyrinth Seals** keep lubricant in and contaminants out

**Heavy-Duty Pump End and Drive End Bearings** selected for long life and reliability

**Heavy-Duty Casing** with integral foot and multi-ribbed discharge flange provides superior resistance to pipe loads and improves reliability

**External Three Bolt Rotor Adjustment** allows impeller clearances to be reset in situ, thereby restoring head and efficiency

**One-Piece, Ductile Iron Bearing Housing** is designed for safety, maximum concentricity, strength and alignment

**Back Pullout Design** allows removal of rotating element without removing casing, piping or motor

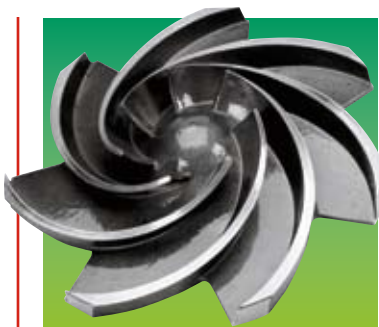

**Precision Cast, Semi-Open Impeller** delivers high efficiency performance and low NPSHR. Standard impeller material is Duplex stainless steel, the strength and hardness of which significantly extend the life of the impeller.

#### **Benefits of CPX Semi-Open Impellers Versus Closed Impellers**

- Adjustability of rotor enables head and efficiency to be restored in situ
- Improved solids handling
- Suitable for a wider range of applications
- Improved seal chamber environment in low NPSH applications
- Smooth entrance profile minimizes snagging of fibrous materials



#### **Reliability and Performance Enhancing Features**

- Precision cast, semi-open impeller with backvanes and shroud cutouts for axial balance reduces maintenance and downtime costs by extending mechanical seal and bearing life
- Precision machined, metal-to-metal inter-connecting faces at the casing, seal chamber and bearing housing for reliable sealing and optimum concentricity
- Robust, solid shaft ensures less than 0.05 mm (0.002 in) deflection at the seal face and low  $L^3/D^4$  ratio, thereby extending mechanical seal life
- Elimination of gaskets avoids leakage and crevice corrosion

#### **Optional Jacketed Casing**

An optional jacketed casing is available for those applications in which the pumped fluid must be heated or cooled to maintain optimal fluid viscosity.

#### **Low Flow Sizes**

The CPX is also available in eight low flow, high head designs. Engineered specifically to cover flows lower than ISO 2858, these low flow pumps eliminate the need for throttling and the associated premature failure.

Additional benefits of low flow CPX pumps:

- Lower initial pump cost
- Smaller motor sizing
- Reduced energy costs
- Greater reliability

#### **Additional Features**

- Standard splash guard
- 3 mm (0.12 in) minimum corrosion allowance
- Magnetic drain plug
- Bull's-eye sight glass



**CPX  
45° Seal Chamber  
Technology**

**Advanced Technology  
Seal Chamber**

The CPX 45° conically shaped seal chamber with integral flow modifiers is designed to redirect solids and slurry away from the seal, back into the flow path of the process liquid.

- Extends seal life
  - Self-venting
  - Self-flushing
  - Self-draining
- Reduces maintenance and repair costs
- Provides a safer environment for personnel
- Permits use of less expensive seal and flush plans
- Improves pump reliability

**45° Conical Seal Chamber  
Provides Design Flexibility**

- Accommodates single, double and tandem seal arrangements
- Accepts single and double cartridge seals to latest ISO or DIN standards
- Accepts Eccentric Pumping Annulus (EPA) circulation system, a wide range of flush plans, and auxiliary systems for maximum reliability
- Provides optional jacketed seal chamber for effective heat transfer in the seal chamber area or across the entire surface area of the process fluid

**Flow Modifiers Extend  
Mechanical Seal Life**

- Redirect flow from circumferential to axial, thereby reducing turbulence and abrasion
- The mechanical seal creates a centrifugal action, pushing suspended solids away from the seal faces and into the return flow created by the modifiers
- Solids and slurry merge into the returning flow path and are flushed out of the seal chamber
- Balanced flow with low pressure drop in the chamber helps keep solids in suspension, minimizing erosive characteristics

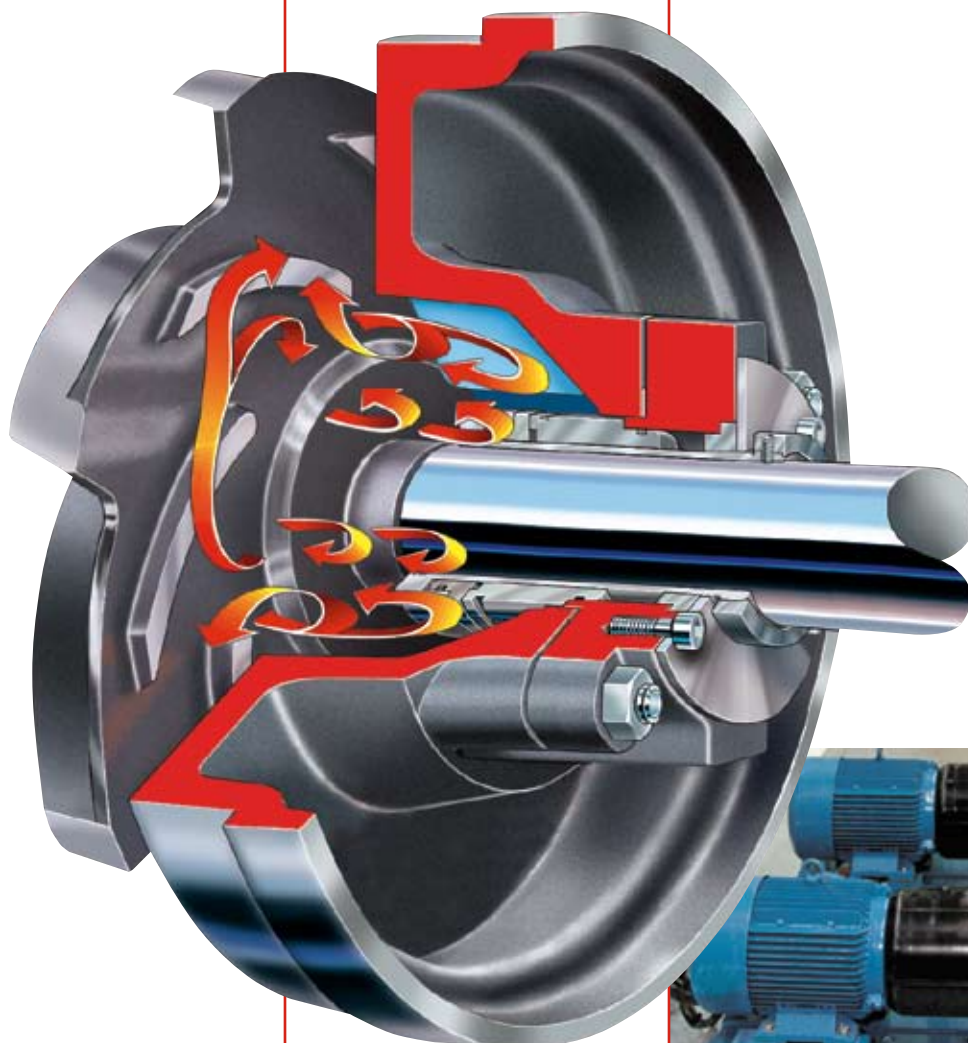

**Optional Integrated  
Solid Seal Cover**

An integral solid seal cover eliminates crevices where corrosion could occur or where potential contaminants could collect, while reducing the parts count.



**CPX  
Mechanical Seals**

The CPX 45° conical seal chamber accommodates many seal types including single, double and tandem arrangements.

The double and tandem seals are available for more severe and environmentally sensitive applications.

All seals can be backed up by a range of flush plans and auxiliary systems.

Conventional single and double cartridge seals can be fitted in accordance with the manufacturer's standard or with those designed to meet the latest ISO or DIN standards.

External seals and gland packing are optional, as is the seal housing jacket which controls the seal environment.

*Single seal with external throttle bush and controlled drain*

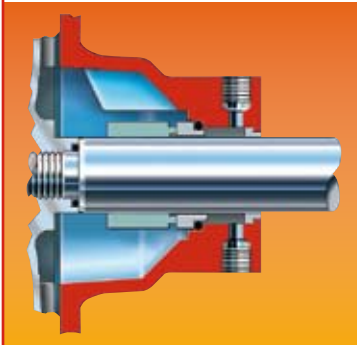

*Single seal with external lip seal*

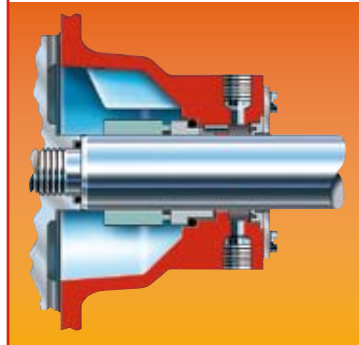

*Single internal seal with internal PTFE neck bush and PTFE throttle bush*

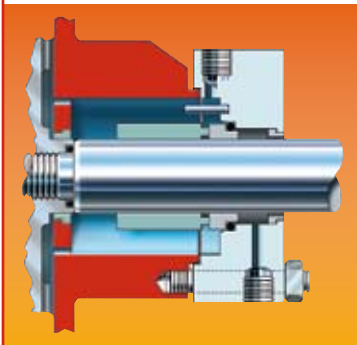

*Double back-to-back seal with EPA circulation*

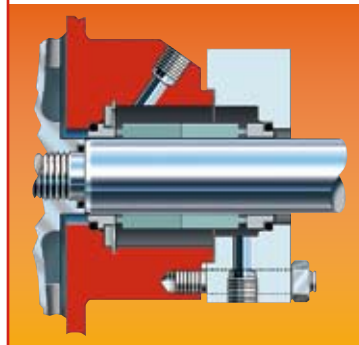

*Tandem seal with EPA circulation*

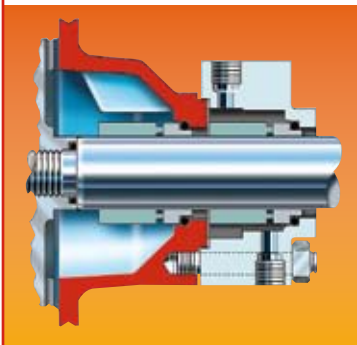

*Double cartridge tandem seal*

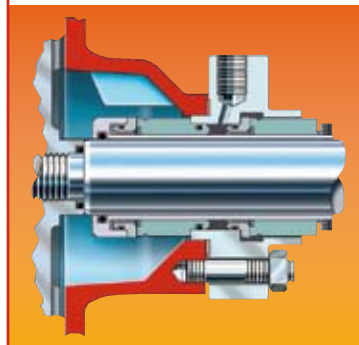

**CPX  
Heavy-Duty  
Shaft and  
Bearings**

CPX shafts and bearings are designed to improve pump reliability. The robust and stiff solid shaft ensures less than 0.05 mm (0.002 in) shaft deflection at the seal face and low  $L^3/D^4$  ratio to maximize mechanical seal life.

**Shaft Materials**

To meet application requirements shafts are available in a wide range of corrosion-resistant materials, including:

- 316 stainless steel
- Duplex stainless steel
- Alloy 20
- Alloy C
- Alloy B

**Bearing Options**



As standard the CPX is supplied with a deep groove ball bearing and double row angular contact thrust bearing providing life in excess of the minimum specified by ISO 5199.

As an optional upgrade, the CPX can be supplied with a deep groove ball bearing and reinforced duplex, back-to-back angular contact thrust bearing, providing L10 bearing life in excess of 50 000 hours.



**Oil Lubricated Bearing Housing** “splash bath” uses bull’s-eye sight glass with magnetic drain plug as standard with constant level oiler as an option.



**Grease Lubricated Bearing Housing** facilitates maintenance by using grease nipples fitted at the pump end and drive end. Alternatively, sealed-for-life bearings can be fitted.

**Additional Options**

- Sealed-for-life bearings
- Additional condition monitoring points
- Tappings for instrumentation and monitoring equipment
- Bearing isolators
  - Standard or proprietary, non-contact designs
- Oil mist lubrication technologies



**Optional non-contacting vapour block bearing isolators**

**CPX  
Parts and  
Materials**

**Flowserve Parts**

Flowserve parts should be specified for all pump maintenance requirements.

In addition to improved maintenance savings only Flowserve offers:

- Parts that are guaranteed to fit, last and perform
- 24-hour emergency service
- Application and materials expertise
- Complete analysis and performance of your maintenance needs with recommended parts inventory and management, if so required



**CPX Materials**

Construction	Casing & Seal Housing	Impeller	Solid Shaft	Sleeved Shaft Option		Bearing Housing
				Shaft	Sleeve	
Ductile Iron	Ductile Iron	Duplex Stainless Steel	316 Stainless Steel	Carbon Steel	316 Stainless Steel	Ductile Iron
Carbon Steel	Carbon Steel					
304 Stainless Steel	304 Stainless Steel					
316 Stainless Steel	316 Stainless Steel				Duplex Stainless Steel	
Duplex Stainless Steel	Duplex Stainless Steel					
Alloy 20	Alloy 20	Alloy 20	Alloy 20	Stainless Steel	Alloy 20	
Alloy C	Alloy C	Alloy C	Alloy C		Alloy C	
Alloy B	Alloy B	Alloy B	Alloy B		Alloy B	

Flowserve foundries are widely regarded as among the world's best. They routinely pour alloys from common austenitic stainless steels to light reactive alloys such as titanium and zirconium.

Attesting to the world class quality of its castings, Flowserve was the first high alloy foundry in the United States of America to have earned approval by Germany's Technischer Uber-wachungs Verein (TUV).



**CPX  
Performance  
Curves and  
Standards  
Compliance**

**CPX Range Chart\***

**2900 rpm**

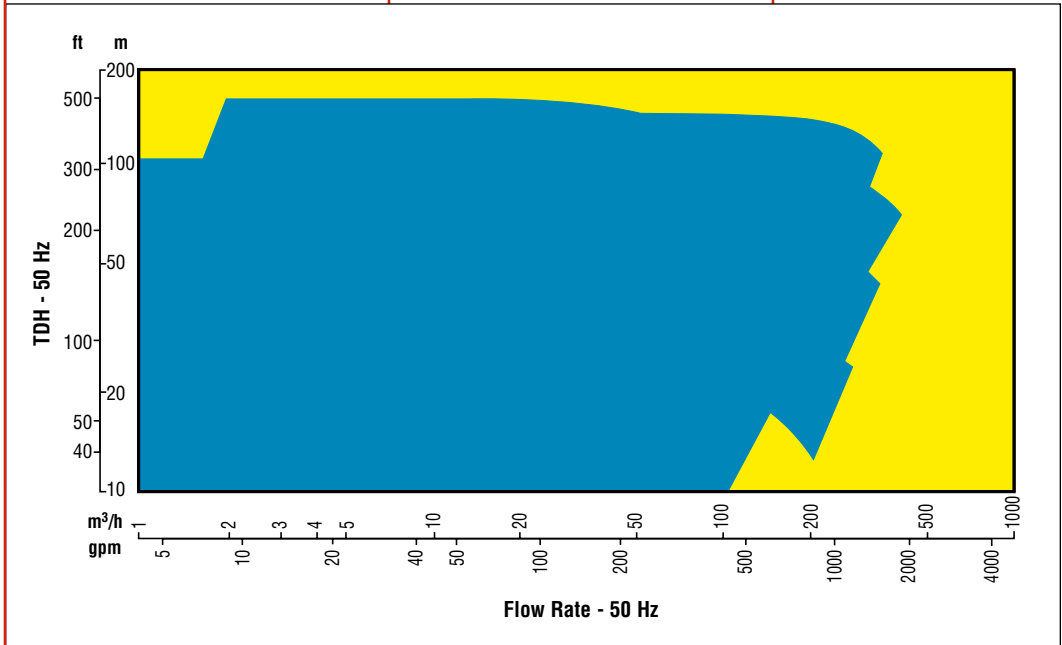

**CPX Range Chart\***

**1450 rpm**

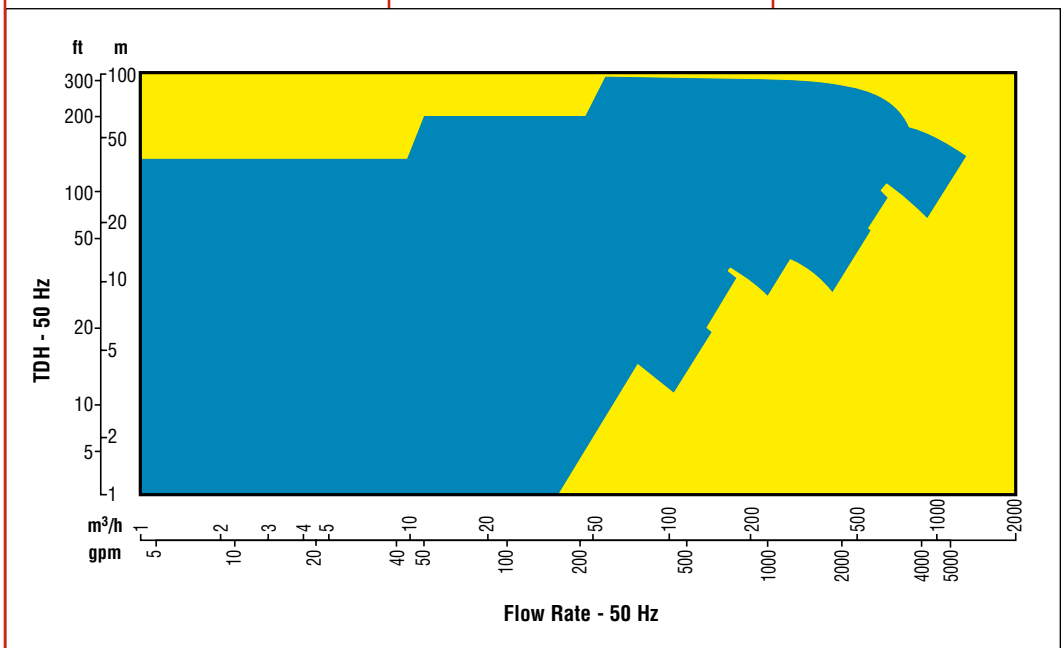

**Standards Compliance**



Compliant to the European ATEX Directive



Compliant to the European CE Directives

\* Pumps can be used on 50 Hz or 60 Hz cycle supply

**CPX**  
**Interchangeability**  
**and PROS+™ SE**  
**System**

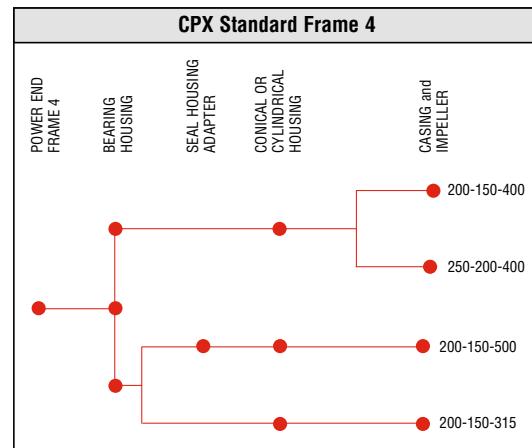
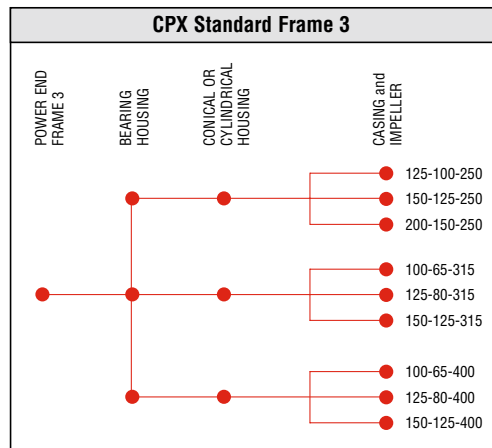
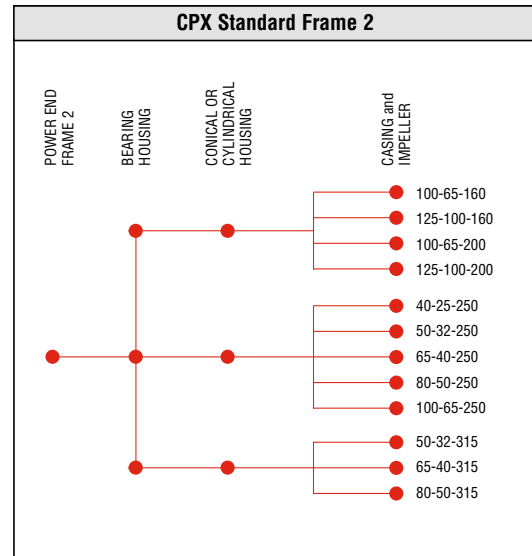
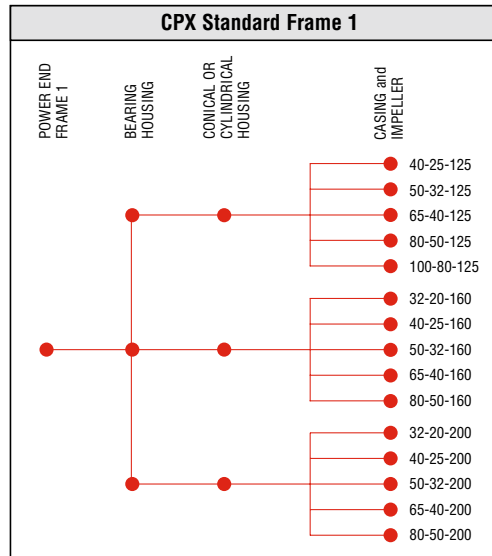

**PROS+**  
 PROS+ proposal and order system is the most comprehensive and user friendly pump selection program in the industry. This software ensures correct sizing and selection of Flowserve pumps to best suit your process application needs.

PROS+ is available from your local sales representative or online at [www.flowserve.com](http://www.flowserve.com).

**PROS+<sup>SE</sup>**  
*Including: Centrifugal Pump Fundamentals*

- Proprietary knowledge-based pump selection program** accessing over 95 Flowserve pump product lines
- Valuable tool** to facilitate process design and engineering estimates
- Electronic communication** of selection and quotation data

*Experience In Motion*

**CPXS  
Magnetic Drive  
Pump**

**Leak-Free Pumping**

The CPXS magnetic drive process pump provides leak-free pumping of hazardous, toxic, flammable, explosive or valuable liquids.

Conforming to ISO 2858 dimensional and ISO 5199 design criteria, the CPXS magnetic drive pump is found wherever reliability in severe services is a requirement.

**Standards Compliance**

The CPXS is CE marked and compliant with applicable European directives, such as ATEX.

**Operating Parameters**

- Flows to 420 m<sup>3</sup>/h (1850 US gpm)
- Heads to 160 m (525 ft)
- Pressures to 25 bar (365 psi)
- Temperatures from -40°C (-40°F) to 250°C (480°F)

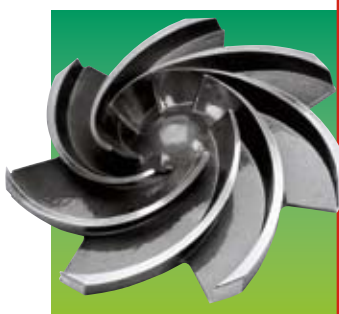
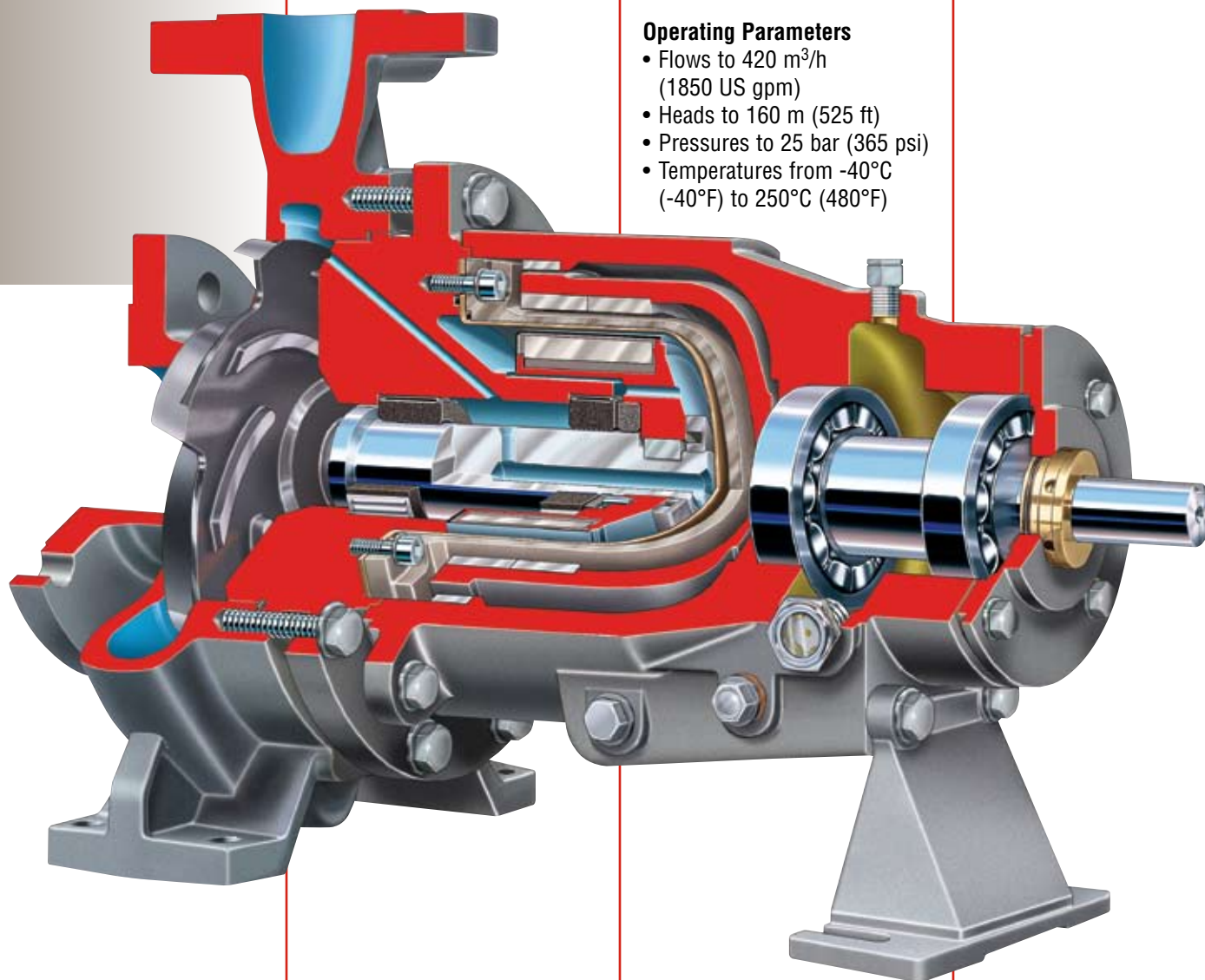

**Precision Cast Semi-Open Impeller** delivers high efficiency performance, low NPSHR, low running cost and long life

**High Performance Rare Earth Magnets** possess superior permanent strength and proven reliability

**Large Inner Magnet Clearances** of 1.5 mm (0.06 in) between shell and inner magnet assembly ensure effective cooling

**Reinforced PEEK Primary Containment Shell** eliminates eddy current losses, enhancing efficiency

**Hastelloy® Primary Containment Shell** may be specified

**Optimized Internal Flow Paths** lubricate bearings and cool magnets

**Upgrading** of mechanically sealed to magnetically driven, sealless pumps is made easy due to the interchangeability between pump bearing frames

© Hastelloy is a registered trademark of Haynes International, Inc.



**Standard Back Pullout** for general maintenance and inspection.

Casing stays in-line and piping connections remain intact.



**KW941 Pump Power Monitor** displays actual power to the pump offering simultaneous protection from under-load and overload operating conditions.



**Contained Back Pullout** for drive end maintenance. Process fluid is fully contained; no

draining, purging or exposure to harmful process fluids.



**Optional Secondary Containment Shell**  
A hydroformed Hastelloy secondary containment shell is available for added security in critical services.

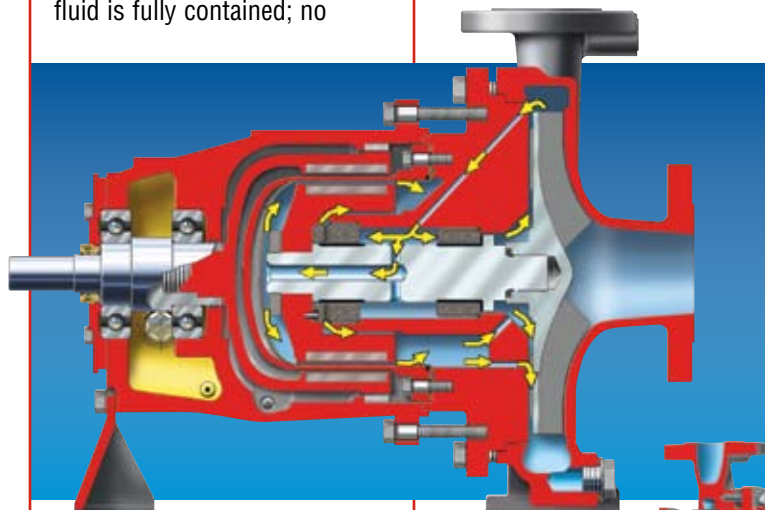

**Flow Circulation Path**  
Through analytical and practical research, Flowserve has developed a unique flow path analysis program to aid in the correct sizing of magnetically driven pumps.

The program calculates flow, temperature and axial thrust within the drive unit, allowing the pump liquid vapour point to be determined.

Using this data, Flowserve is able to appropriately select and size pumps, preventing liquid vapourization in the drive unit and the associated damage.

**CPXSM**  
Close coupled configuration also available.



**CPXM  
Close Coupled  
Pump**

**Space Saving Configuration**

With pump ends conforming to ISO 2858 dimensional and technical standards and to ISO 5199 design criteria, the CPXM provides a compact, space-saving arrangement ideal for industrial processes or installations when space is at a premium.

CPXM pumps are fitted with standard, readily available electric motors so the user can choose an enclosure to suit the application.

**Operating Parameters**

- Flows to 570 m<sup>3</sup>/h (2500 US gpm)
- Heads to 125 m (400 ft)
- Pressures to 25 bar (365 psi)
- Temperatures from -20°C (-5°F) to 160°C (320°F)

**Applications**

- Acid transfer
- Caustic and chlor-alkali
- Man-made fibers
- Polymers
- Slurry processing
- Solvents
- Volatile organic compounds
- Waste processing

**Standards Compliance**

The CPXM is CE marked and compliant with applicable European directives, such as ATEX.

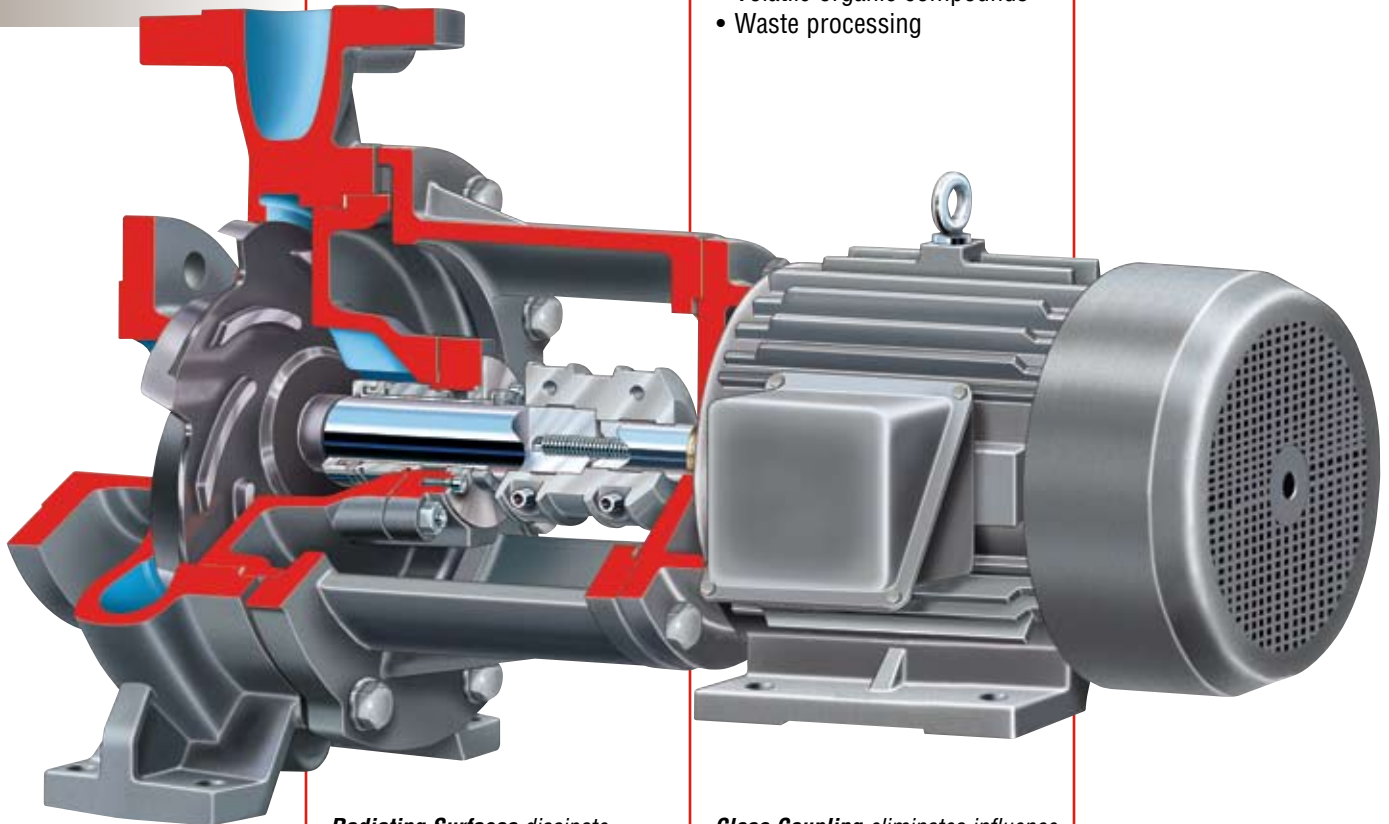

**Radiating Surfaces** dissipate heat and extend bearing and mechanical seal life

**External Impeller Adjustment** can be carried out without taking measurements

**Heavy-Duty Casing** with integral foot and multi-ribbed discharge flange provides superior resistance to pipe loads

**Close Coupling** eliminates influence of the baseplate and foundation on alignment

**Optional Secondary Seal** controls leakage in the event of primary seal failure, providing increased safety and reduced pump downtime

Available with most of the standard and optional features of the CPX ISO frame mounted pump

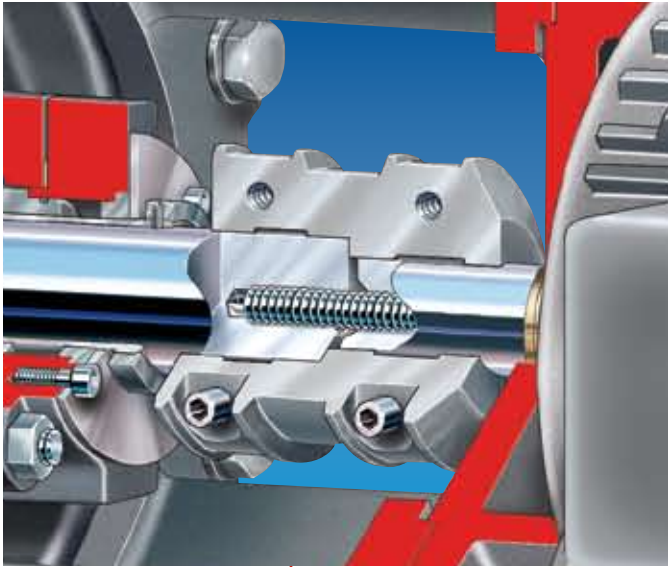

**Benefits of CPX Close Coupling Design**

- Permits use of readily available standard electric motors
- Provides a thermal barrier between pump and motor
- Reduces installation cost by eliminating pump to motor alignment
- Serves as an additional deflector between mechanical seal and motor

**Other Configurations**



**CPXRM**

Close coupled, recessed impeller pump



**CPXPM**

Close coupled, self-priming pump

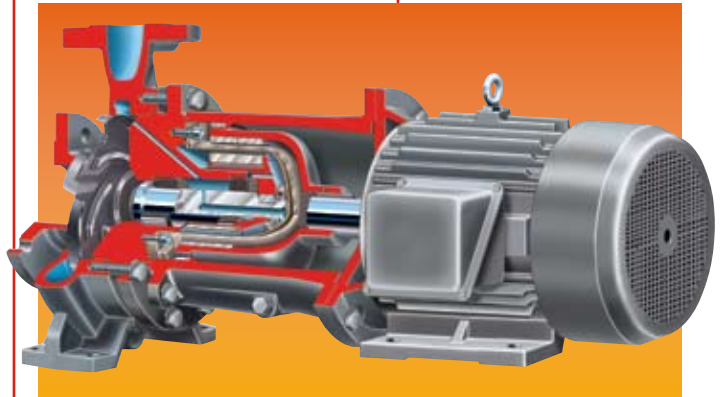

**CPXSM**

Close coupled, magnetic drive pump



**CPXM**

**CPXP  
Self-Priming  
Pump**

**Surface Mounted Design**  
Costing less to buy, install and maintain than submersible pumps, the CPXP self-priming pump is designed to draw from liquid sources below ground level or from sources with no positive pressure to naturally prime the pump. Its compact

design enables it to fit in tight clearance locations. It can be easily mounted on a trailer for movement to various pumping locations such as wastewater lagoon service.

**Standards Compliance**  
The CPXP is CE marked and compliant with applicable European directives, such as ATEX.

**Operating Parameters**

- Flows to 250 m<sup>3</sup>/h (1100 US gpm)
- Heads to 130 m (425 ft)
- Pressures to 25 bar (365 psi)
- Temperatures from -80°C (-110°F) to 350°C (660°F)

**Applications**

- Sump service
- Tanker unloading
- Marine and river extraction
- Wastewater and effluent
- Dewatering
- Vessel transfer

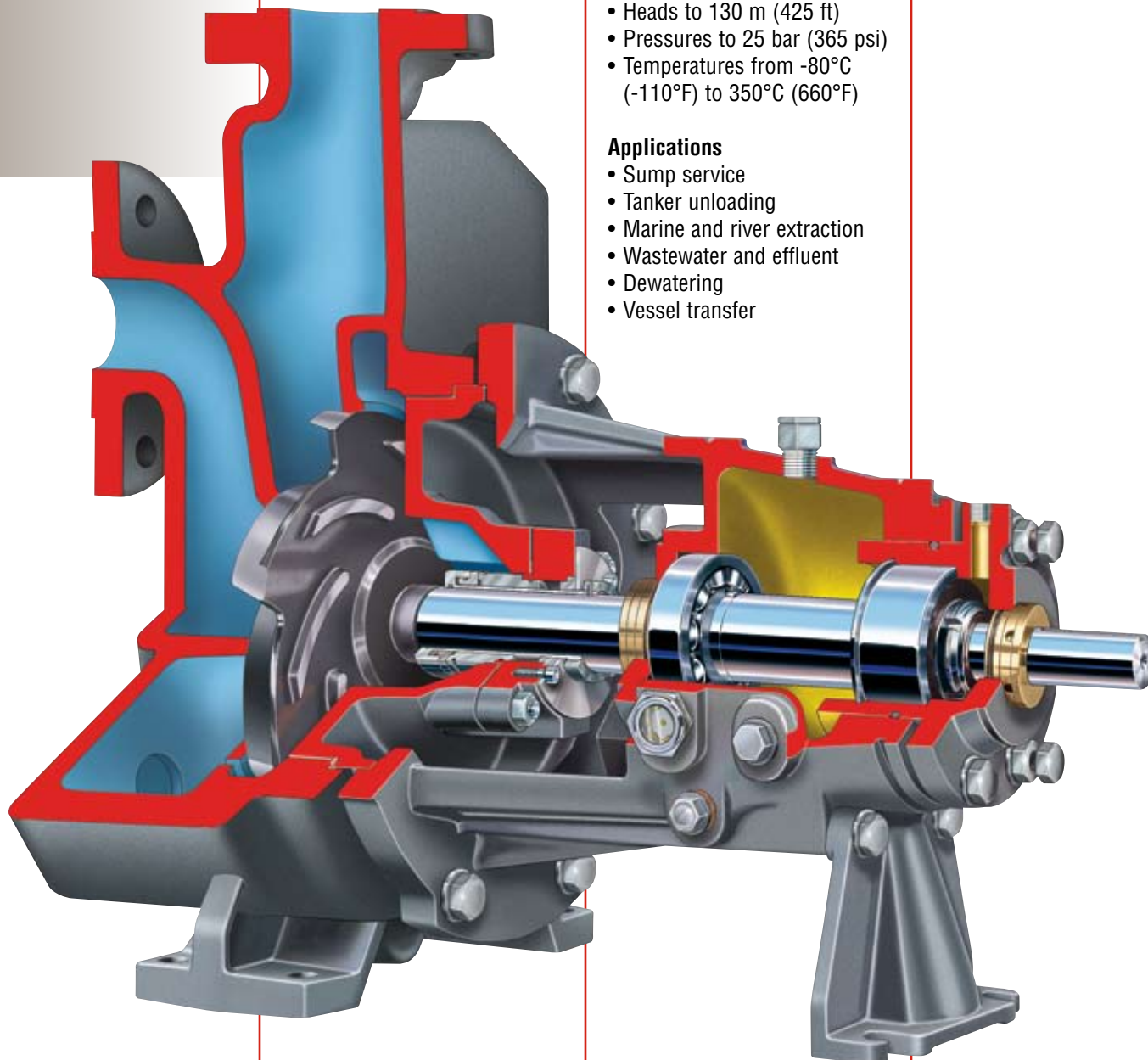

**One-Piece Casing** has large priming chamber, air separator and volute in one integral component, keeping components to a minimum

**Semi-Open Impeller** delivers high efficiency performance, low NPSHR and good solids handling

**Reflux Priming Principle** eliminates the need for internal valves and external priming devices

**Suction Run Dry Capability** allows for minimum supervision

**The Reflux Priming Principle**

The CPXP self-priming pump operates on the reflux principle, using liquid recirculation to prime the pump. The pressure differential between the aerated liquid at the impeller and the

non-aerated liquid in the priming chamber creates a vacuum that pulls liquid up the pipe.

This principle eliminates the need for both internal valves and external priming devices or foot-valves. As a result, CPXP is ideal for suction lift applications or where a process involves pumping a liquid with air or gas phases.

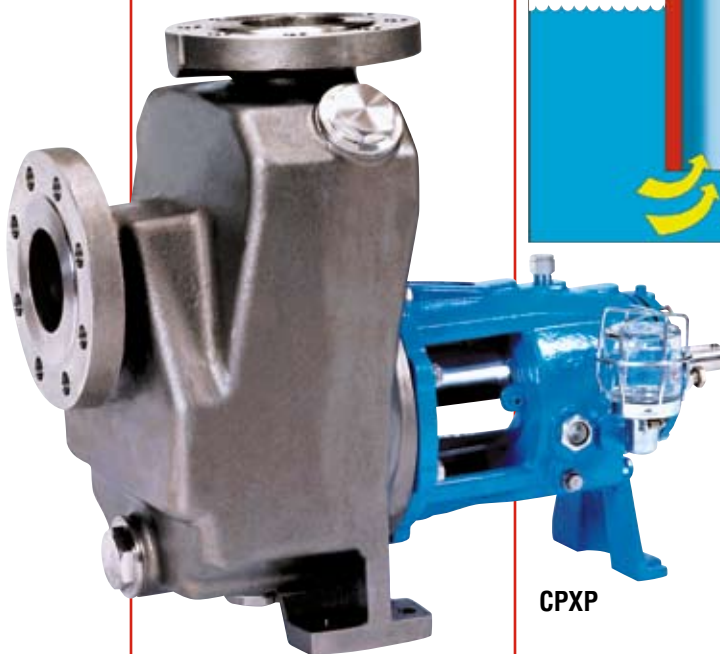
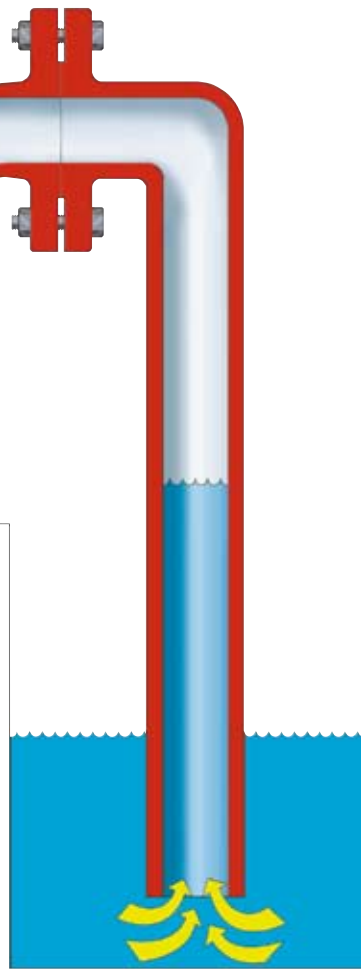
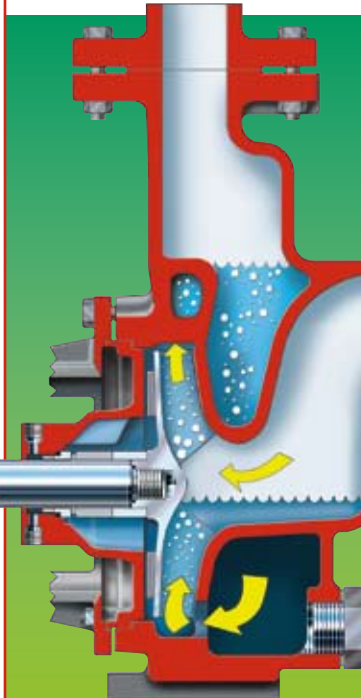

CPXP



**Semi-Open Impeller**  
for high efficiency, low NPSHR and good solids handling.



**Advanced Technology 45° Conical Seal Chamber** with integral flow modifiers redirects solids and slurry away from seal and back into the flow path of the process liquid, extending seal life and improving pump reliability.

**Additional Configurations**

- **CPXPM**  
Close coupled, self-priming pump
- **CPXPS**  
Magnetically driven, self-priming pump
- **CPXPMSM**  
Close coupled, magnetically driven, self-priming pump

**CPXR  
Recessed  
Impeller Pump**

**Low-Shear Pumping**

The CPXR recessed impeller pump provides low-shear pumping of friable solids and trouble-free pumping of stringy or fibrous slurries. It combines the state-of-the-art hydraulics of the CPX with the vortex action of a recessed impeller.

The CPXR has a wide clearance at the front of the semi-open impeller allowing passage of larger particles. Solids are drawn into the vortex of swirling liquid and discharged by centrifugal force through the open area in front of the impeller with little contact, minimizing particle degradation. Furthermore, the air and gas handling capability of the pump is improved.

**Operating Parameters**

- Flows to 750 m<sup>3</sup>/h (3300 US gpm)
- Head to 100 m (330 ft)
- Pressures to 25 bar (365 psi)
- Temperatures from -80°C (-110°F) to 350°C (660°F)

**Applications**

- Light slurries
- Corrosive/erosive services
- Large diameter solids
- Waste streams
- Shear-sensitive fluids
- Friable solids
- Fibrous materials

**Standards Compliance**

The CPXR is CE marked and compliant with applicable European directives, such as ATEX.

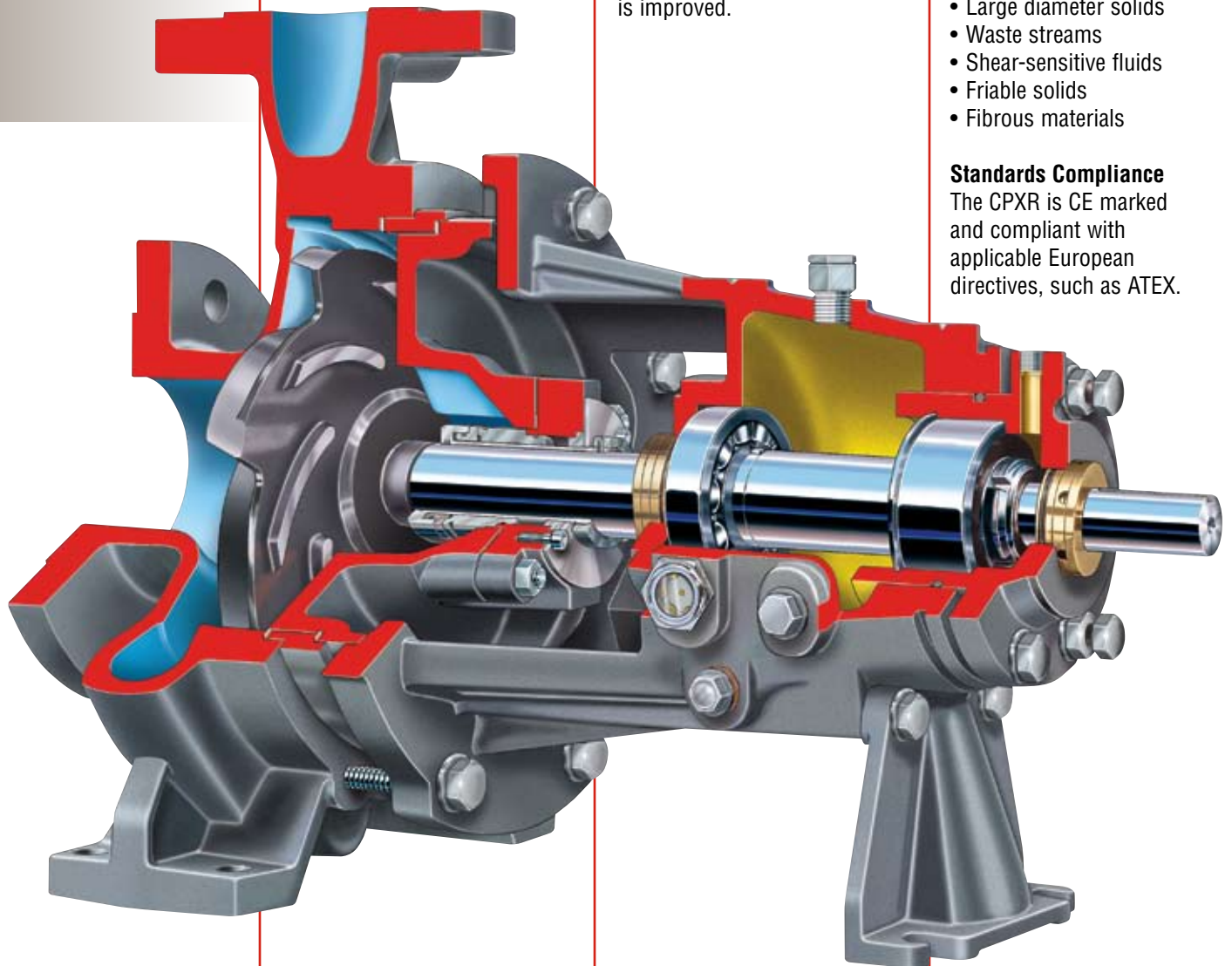

**Advanced 45° Conical Seal Chamber** with integral vortex flow modifiers increases mechanical seal life

**Standard Non-Contacting Labyrinth Seals** keep lubricant in and contaminants out

**Heavy-Duty Pump End and Drive End Bearings** selected for long life and reliability

**Vortex Action** causes only a fraction of the media to contact the impeller, minimizing abrasive wear and maintaining solids integrity

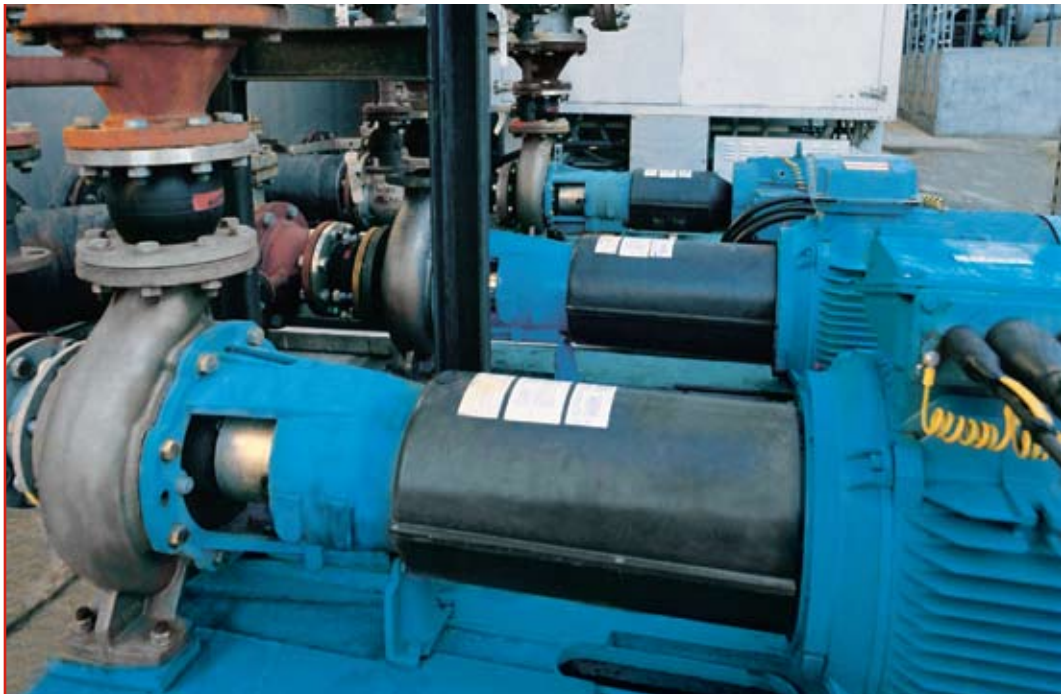

**Benefits of the CPXR**

- Improved solids handling
- Improved air and gas handling
- Improved ability to pass fibrous or stringy materials
- Reduced wear

**Other Features**

- Back pullout design
- Non-contacting labyrinth seals
- Bosses for inlet and outlet pressure gauges

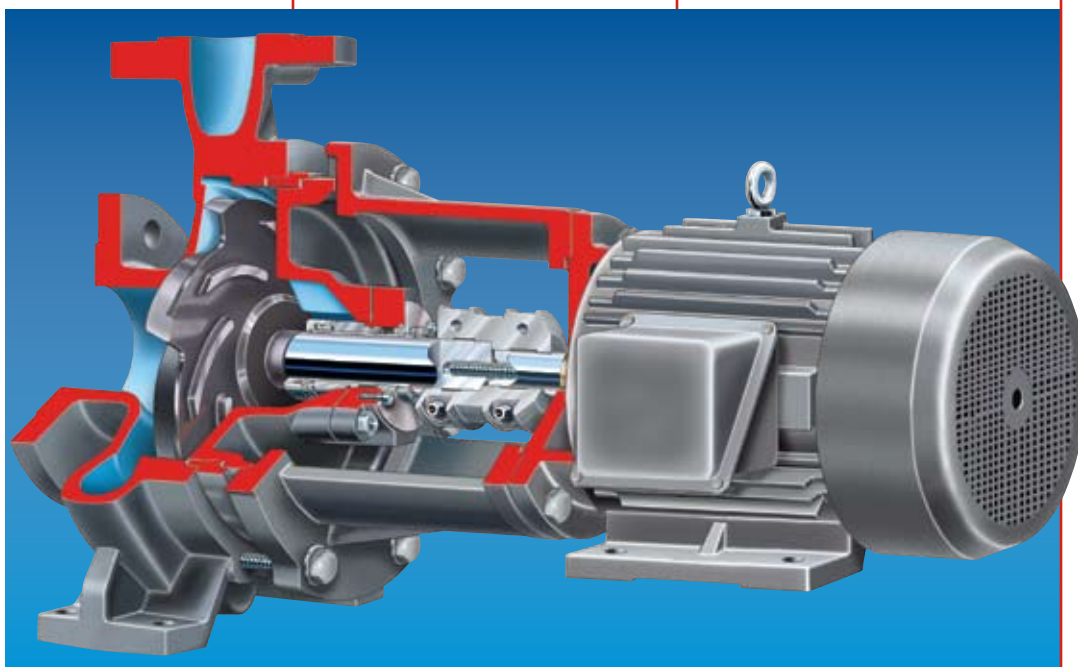

**CPXRM**

**Precision Cast, Semi-Open Impeller** delivers high efficiency performance, low NPSHR and long life.

- Backvanes and shroud cutouts for axial balance extend seal life and bearing reliability
- Impeller is screwed to the shaft for high strength and improved shaft end corrosion resistance

**Additional Configurations**

- **CPXRV**  
Recessed impeller, vertical pump
- **CPXRM**  
Recessed impeller, close coupled pump

**CPXV  
ISO & API  
Vertical Sump  
Pump**

**Vertical Sump Pump**

The Flowserve CPXV is a vertical sump pump incorporating state-of-the-art hydraulic design for efficient and reliable service.

The CPXV can be customized to meet a wide range of needs. Compliant with ISO 5199, the CPXV is available in 40 hydraulic wet-ends and a wide variety of materials of construction. It is also available with multiple mechanical seal options and sump depths.

The CPXV is also available in an API 610 compliant version.

**Operating Parameters**

- Flows to 1400 m<sup>3</sup>/h (6160 US gpm)
- Heads to 250 m (820 ft)
- Temperatures from -40°C (-40°F) to 350°C (660°F)
- Pressures to 25 bar (365 psi)
- Speeds to 4700 rpm

**Modular Construction** ensures installation flexibility with a standard column length of 0.5 m (1.6 ft), which equates to a minimum sump depth of 0.7 m (2.3 ft)

**Additional Column Lengths** are provided up to a maximum of 10 m (32 ft)

**Heavy-Duty Thrust Bearings** with axial adjustment made at soleplate level

**Recessed Impeller** version is available for enhanced solids handling capability

**Suction Strainer** optional

**Fully Jacketed** version is available for molten sulfur applications

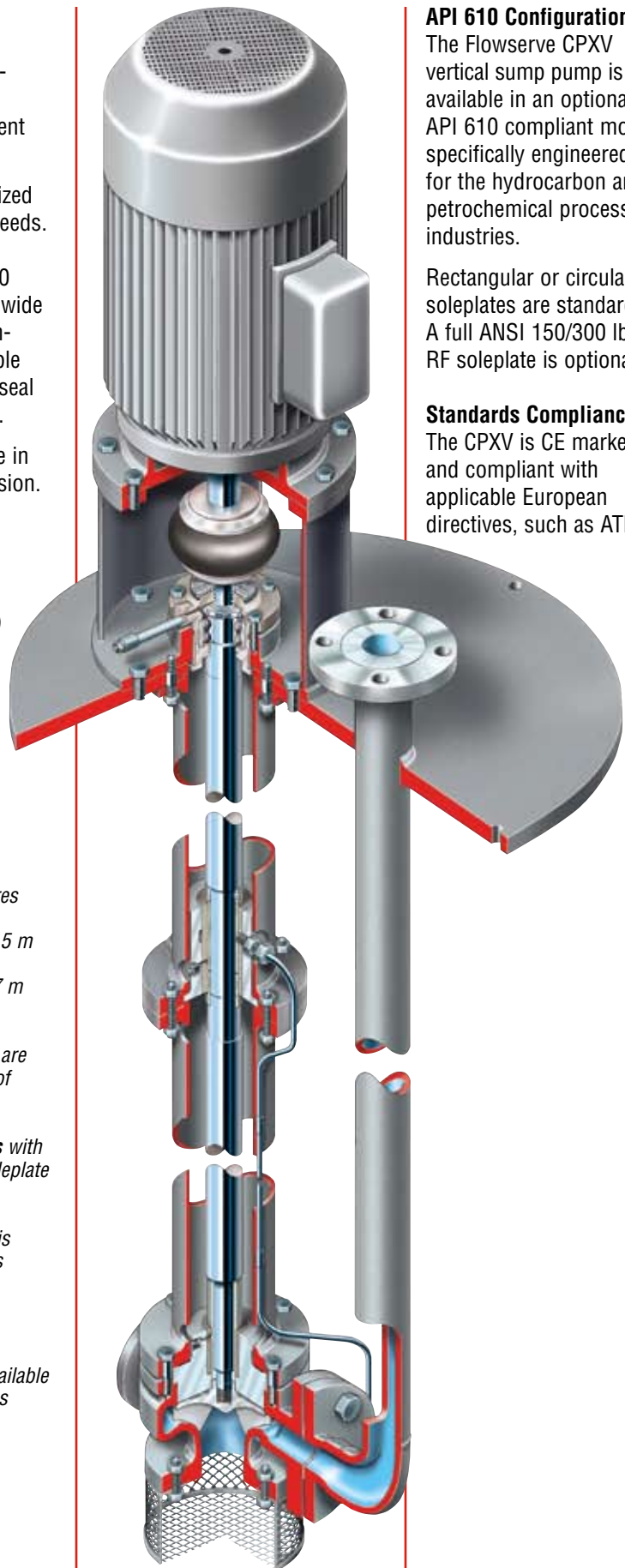

**API 610 Configuration**

The Flowserve CPXV vertical sump pump is also available in an optional API 610 compliant model, specifically engineered for the hydrocarbon and petrochemical processing industries.

Rectangular or circular soleplates are standard. A full ANSI 150/300 lb RF soleplate is optional.

**Standards Compliance**

The CPXV is CE marked and compliant with applicable European directives, such as ATEX.

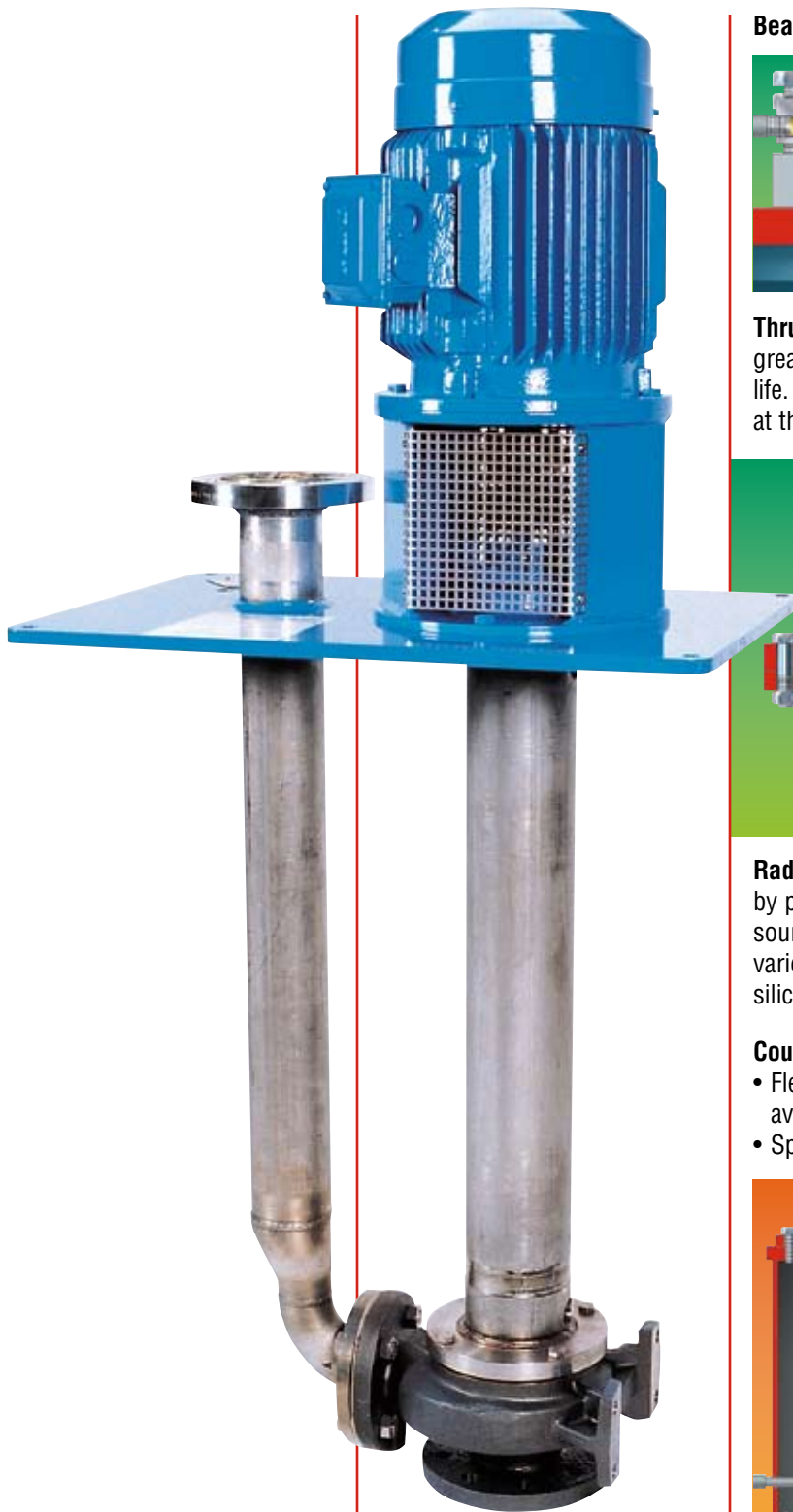

**Bearing Options**

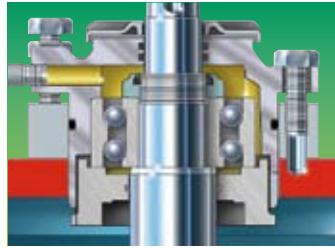

**Thrust Bearings** are heavy-duty grease lubricated or sealed-for-life. Either allows axial adjustment at the soleplate.

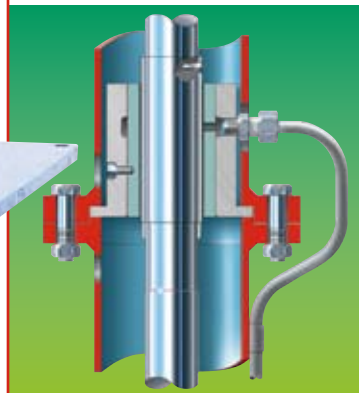

**Radial Bearings** can be flushed by product or from an external source and are available in a variety of materials, including silicon carbide.

**Couplings**

- Flexible disc coupling available
- Spacer coupling available

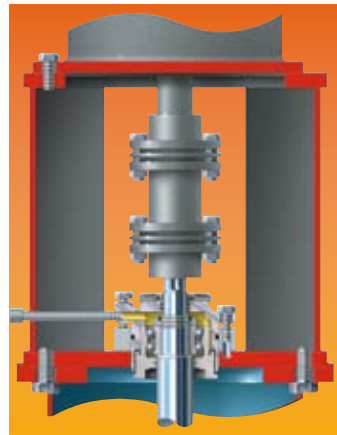

**Optional Spacer Coupling**

**Mechanical Seal Options**

A variety of mechanical seal options are available, from simple vapour sealing to tandem cartridge.

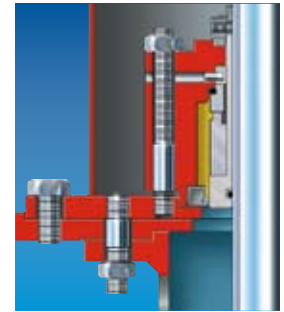

**Unbalanced Mechanical Seal**

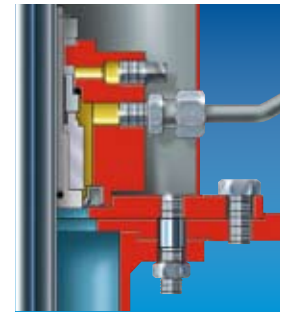

**Balanced Mechanical Seal**

**Additional Options**

- Recessed impeller
- Vapour/mechanical seal option
- Fully jacketed version
- Various motor enclosures
- Rectangular or circular soleplates
- Full ASME (ANSI) Class 150/300 RF soleplate
- Non-spacer coupling
- Oil lubrication to thrust bearing

**Flowserve  
Pre-Engineered  
Baseplate Designs**

**Extend MTBPM and Reduce Maintenance Costs**

The Flowserve family of pre-engineered baseplate designs further extends MTBPM by reducing internal pump stress and vibrations. That is why Flowserve recommends reinforced rigid baseplates.

Flowserve offers a broad range of metallic and non-metallic, grout and stilt mounted designs with standard options. This provides flexibility in choosing the baseplate that best meets application needs and operating budget.

**Standard steel baseplate**



**Cast iron baseplate**



**PolyBase™ baseplate – foundation or stilt mounted**



**Reinforced baseplate – spring stilt mounted**



**Baseplate Materials**

- Cast iron
- Steel
- Rolled steel
- Stainless steel
- Polymer concrete
- Solid polymer

**Baseplate Options**

- Stilt mounting
- Spring mounting
- Drain rims, pans, and connections
- Polycrrete mounts
- Motor feet adjusters
- Earthing points
- Baseplates to ISO 3661 and API 610 standards
- Inertia baseplates

**Polybase™ – Solid Polymer Concrete Baseplate**

- Low installed cost
- Superior vibration dampening
- Corrosion resistant
- Superior resistance to twisting or diaphragming
- Designed to be flat
- Available with or without catch basin and grout holes
- Inserts can be located to mount alternate equipment configuration requirements

**Flowserve  
Polyshield  
Polymer  
Baseplate and  
Foundation  
System**

The Flowserve Polyshield baseplate and foundation system is the superior solution for cost effective, high performance pump installation. In one complete unit, it combines the traditional baseplate and formed concrete foundation for pump-drive sets.

**Benefits of Selecting the Polyshield Baseplate and Foundation System**

- Time savings
  - Quick installation time
  - Reduces time span from receipt at jobsite to commissioning
- Cost savings
  - Reduces total installed cost
  - Dramatically minimizes field rework necessary to meet specifications
- Better performance and reliability
  - Improved MTBPM
  - Reduced vibration
  - Improved corrosion resistance
- Single structure convenience
  - One-piece construction
  - Flat mounting surfaces
  - One-piece motor mounting block

The Polyshield baseplate and foundation system can be combined with numerous pump designs, including:

- ISO and ASME (ANSI) metallic and non-metallic
- Foot- and frame-mounted general industrial
- Foot-mounted between bearing
- API 610

*Please see Bulletin PS-90-2 for more complete product information*

*Product literature available at [www.flowserve.com](http://www.flowserve.com)*

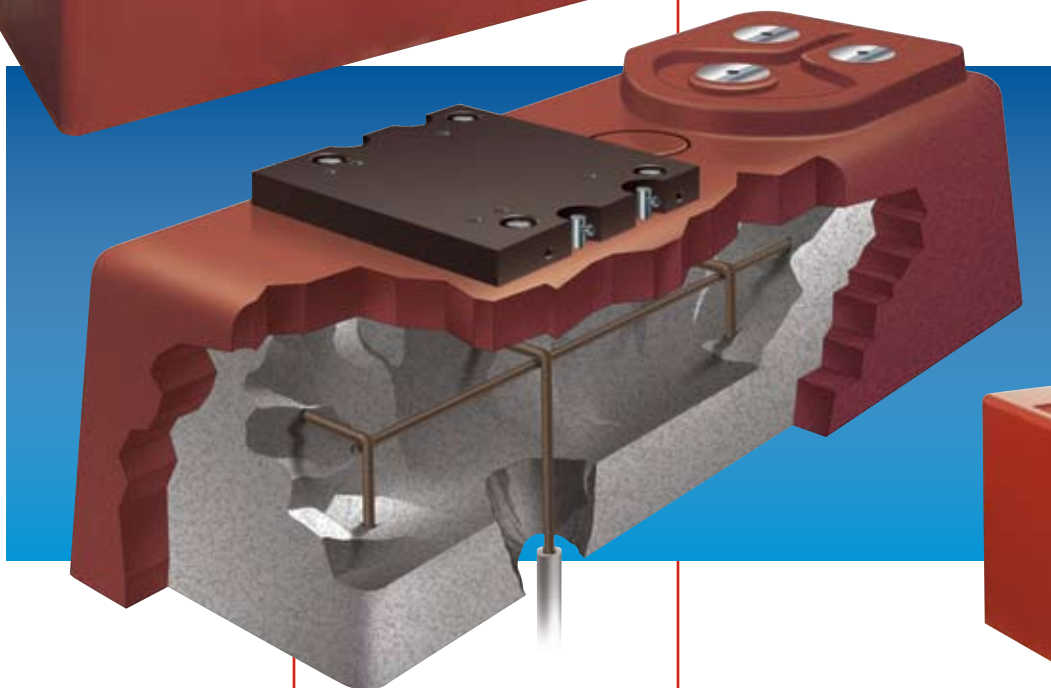
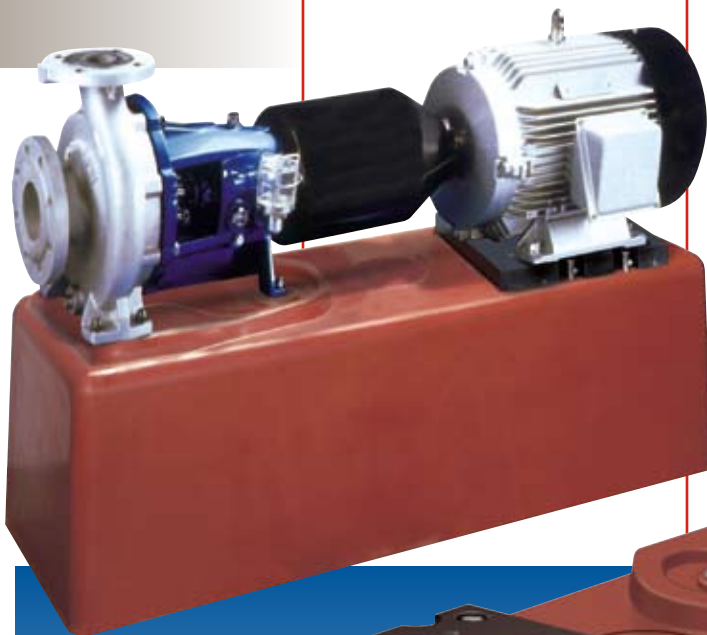

**Flowserve  
PolyChem™  
and GRP  
Non-Metallic  
Process Pumps**

**PolyChem Non-Metallic  
Process Pumps**

The Flowserve PolyChem non-metallic pump is available in ISO, ASME (ANSI), and JIS configurations to meet global demands. Its PFA lined wet end offers outstanding corrosion resistance and temperature resistance to 150°C (300°F).

**PolyChem S-Series Sealed  
Pump Operating Parameters**

**Capacities**

- 60 Hz: to 320 m³/h (1400 US gpm)
- 50 Hz: to 260 m³/h (1150 US gpm)

**Heads**

- 60 Hz: to 230 m (760 ft)
- 50 Hz: to 160 m (530 ft)

**PolyChem S-Series**

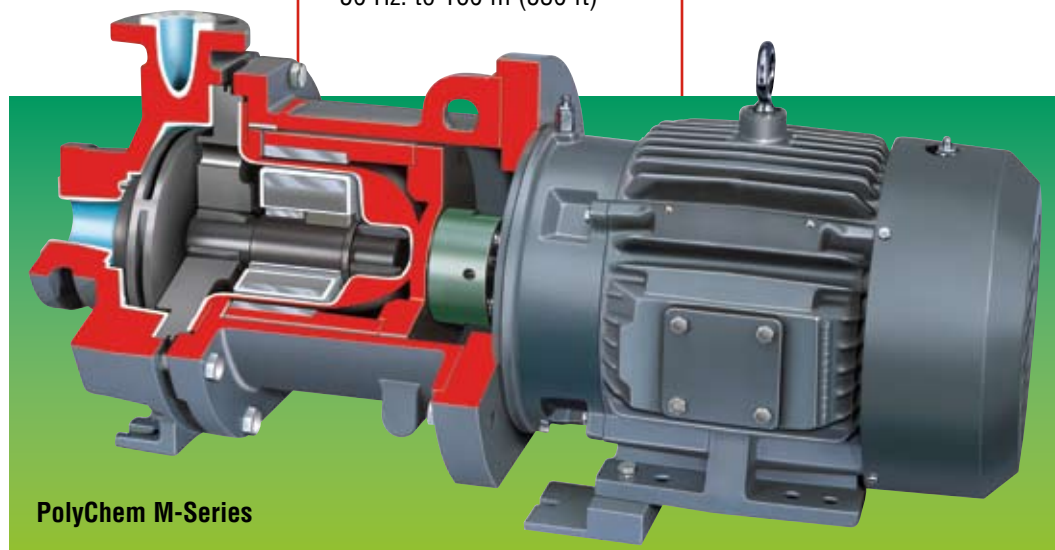
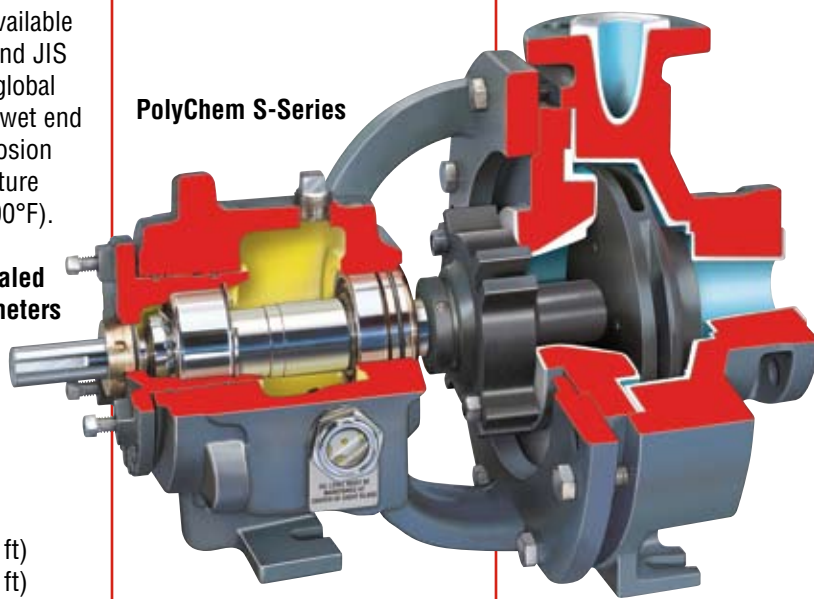

**PolyChem M-Series**

**PolyChem M-Series  
Magnetic Drive Pump  
Operating Parameters**

**Capacities**

- 60 Hz: to 170 m³/h (750 US gpm)
- 50 Hz: to 140 m³/h (625 US gpm)

**Heads**

- 60 Hz: to 135 m (450 ft)
- 50 Hz: to 95 m (310 ft)

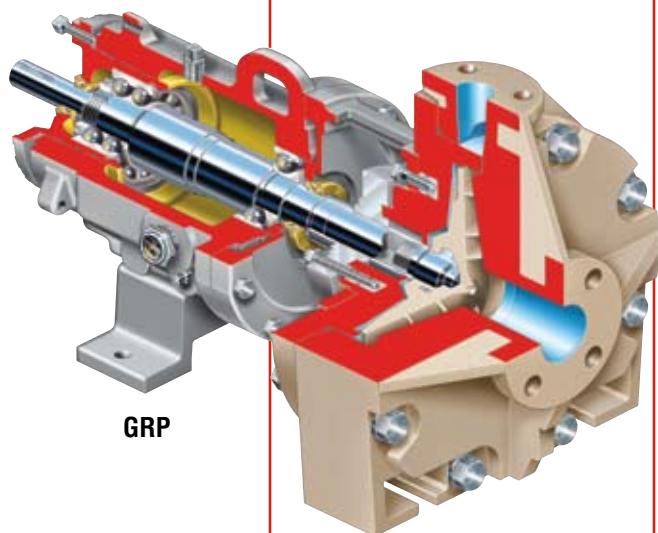

**GRP**

**GRP Non-Metallic Pump**

The Flowserve GRP non-metallic pump is designed to ASME (ANSI) B73.5 M standards. Having corrosion resistance superior to more expensive, high alloy metals, the GRP costs only slightly more than ductile iron. The GRP pump has proven to be the low-cost, long-term solution in corrosive applications.

**Operating Parameters**

- Flows to 2500 m³/h (11 000 US gpm)
- Heads to 150 m (500 ft)
- Pressures to 17 bar (250 psi)
- Temperatures to 120°C (250°F)

*Product literature available at [www.flowserve.com](http://www.flowserve.com)*

**Flowserve  
Mark 3 ASME  
Standard and  
In-Line Pumps**

**Mark 3 ASME (ANSI) Standard**

With its reverse vane impeller, SealSentry™ family of seal chambers, and the optional ANSI 3A™ power end, the Mark 3 Standard pump is recognized worldwide as the premier name in ASME (ANSI) chemical process pumps.

**Thirty Sizes**

- Seven Group 1
- Sixteen Group 2
- Seven Group 3

**Capacities**

- 60 Hz: to 1680 m<sup>3</sup>/h  
(7400 US gpm)
- 50 Hz: to 1390 m<sup>3</sup>/h  
(6120 US gpm)

**Heads**

- 60 Hz: to 300 m (985 ft)
- 50 Hz: to 200 m (655 ft)

*Please see Bulletin P-10-500  
for more complete product  
information*

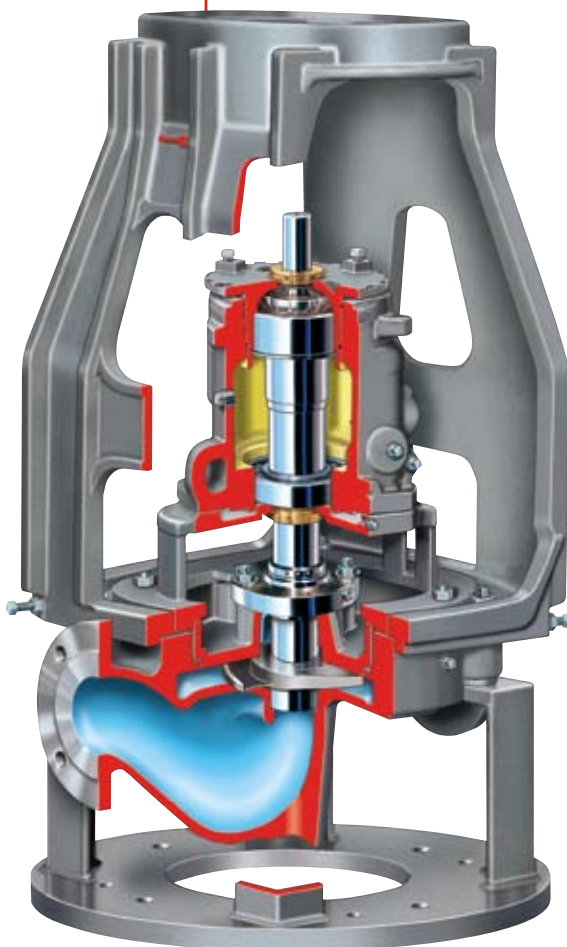
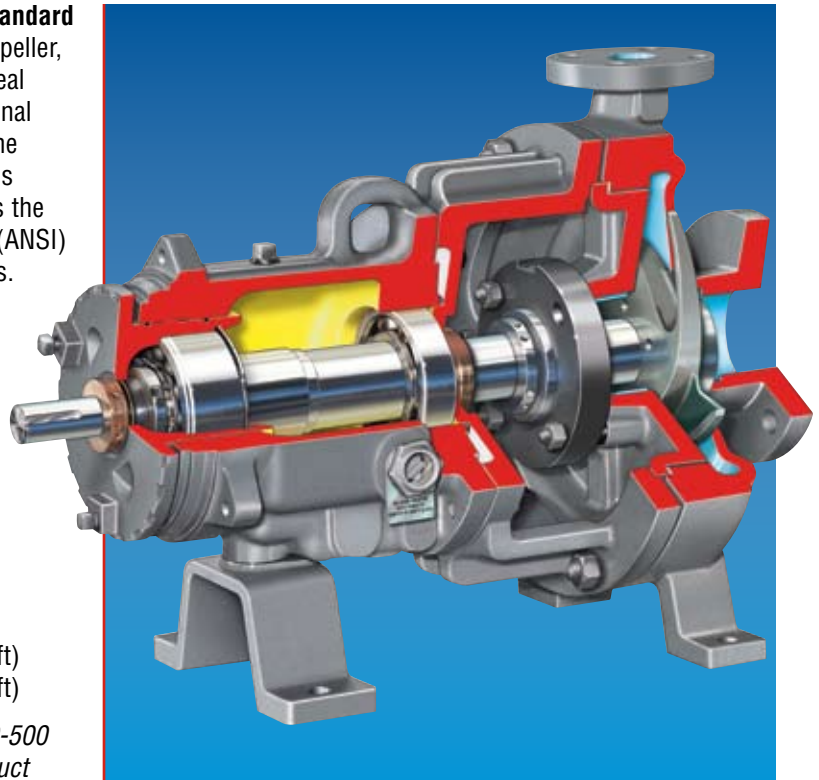

**Mark 3 In-Line**

The Mark 3 In-Line ASME (ANSI) pump, with its own independent bearing housing and rigid style motor adapter, remains one of the most reliable process pump designs available.

Nine sizes available

**Capacities**

- 60 Hz: to 370 m<sup>3</sup>/h  
(1630 US gpm)
- 50 Hz: to 290 m<sup>3</sup>/h  
(1280 US gpm)

**Heads**

- 60 Hz: to 140 m (460 ft)
- 50 Hz: to 95 m (315 ft)

*Please see Bulletin PS-10-15  
for more complete product  
information*

*Product literature available at  
[www.flowserve.com](http://www.flowserve.com)*

## Engineered Pumps

### ERP Centerline Mounted Process Pump

The ERP is the pump of choice for severe chemical, petrochemical, refining and heavy duty industrial service applications where full compliance with API 610 is not required.

#### Operating Parameters

- Flows to 1100 m<sup>3</sup>/h (4800 US gpm)
- Heads to 230 m (755 ft)
- Working pressures to 60 bar (870 psi)
- Temperatures to 350°C (660°F)

*Please see Bulletin PS-10-20 for more complete product information*

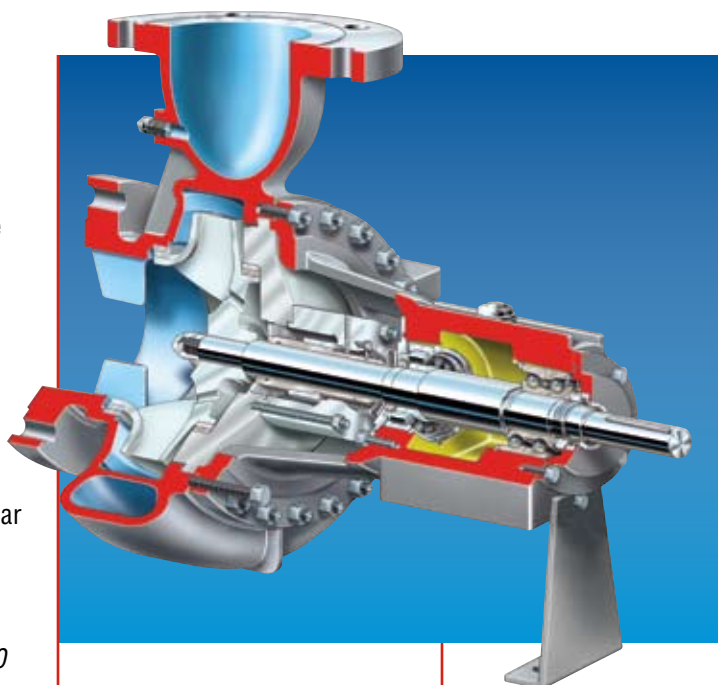

### MSP Vertical In-Line Medium Speed Pump

Closely following API 610, 8th edition design criteria, the MSP vertical in-line medium speed pump is specifically designed for low flow, high head applications. Available in one and two stage designs.

#### Operating Parameters

- Flows to 25 m<sup>3</sup>/h (110 US gpm)
- Heads to 600 m (1970 ft)
- Pressures to 100 bar (1450 psi)
- Temperatures to 200°C (390°F)

*Please see Bulletin PS-10-1 for more complete product information*

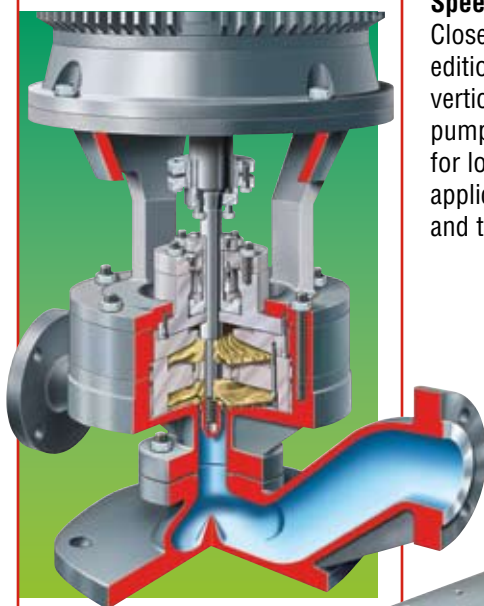

### HPX API 610 Hydrocarbon Processing Pump

Fully compliant with API 610, latest edition design criteria, the HPX pump is the workhorse of the hydrocarbon processing industry due to its unequalled versatility, reliability and hydraulic coverage. The most stringent emissions containment is achieved as the API 682 seal chamber accommodates all combinations of seal models and styles, including advanced barrier seal technology.

#### Operating Parameters

- Flows to 2000 m<sup>3</sup>/h (9000 US gpm)
- Heads to 350 m (1100 ft)
- Pressures to 80 bar (1160 psi)
- Temperatures to 450°C (850°F)

*Please see Bulletin PS-10-5 for more complete product information*

*Product literature available at [www.flowserve.com](http://www.flowserve.com)*

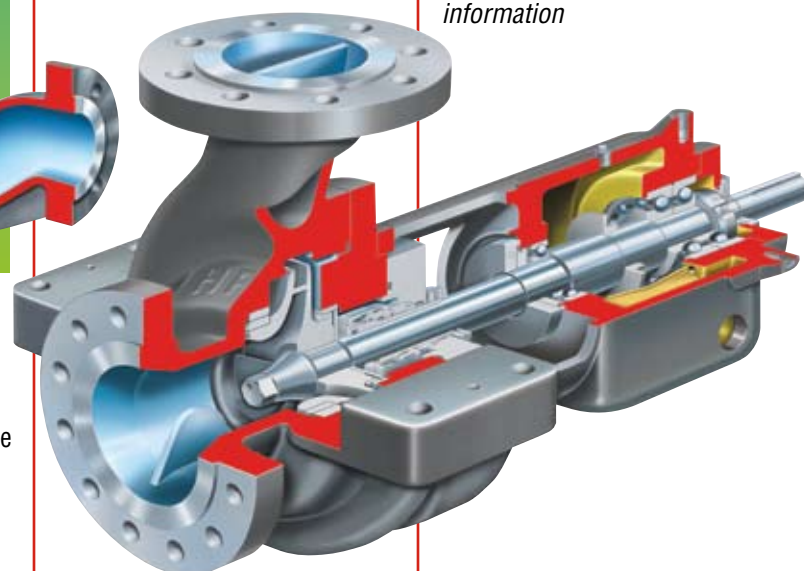

**Global Engineered Services and Support**

- Total Cost Reduction*
- Asset Management*
- Product Life Cycle*
- Performance Re-rates*
- Site Diagnostics*
- Repair Services*
- Energy Management*
- Spare Parts*
- Maintenance Contracts*
- Materials Upgrades*
- Turnkey Services*
- Field Repairs*
- Installation*
- Project Supervision*
- Commissioning*
- Equipment Upgrades*
- Condition Monitoring*
- Systems Analysis*
- Field Machining*

**Service Dedication**

Flowserve Engineered Services is focused on providing customers with uncompromising service and support, where and when needed. Engineered Services is dedicated to delivering the highest quality support by integrating its extensive pump and materials engineering knowledge with creative service solutions. Engineered Services prides itself in understanding the business challenges facing customers and is prepared to manage solutions to succeed as a team.

A worldwide network of service and repair centers staffed by highly skilled engineers and technicians is available around the clock, seven days a week to respond to customer queries, to evaluate and troubleshoot problems and to provide reliable solutions.



**Strength of Experience, Commitment to Excellence**

Flowserve has long served industries requiring superior equipment performance and service life.

- Oil and gas production
- Hydrocarbon processing
- Chemical processing
- Water resources
- Power generation
- Nuclear
- Mining and mineral processing
- Pulp and paper
- General industry

Engineered Services is dedicated to maximizing equipment performance and providing reliability-centered maintenance programs for pumps and related equipment, regardless of manufacturer. Using the FlowStar™ asset management software, Engineered Services tracks performance and supports improvement programs using a service life cycle cost business approach. The results are improved reliability and increased profitability.

**Your Business Partner**

Flowserve partners with customers to respond to the dynamic business conditions that affect them. Flowserve will work with customers to drive efficiency, maximize throughput and control process quality. Whether your needs involve on-site technical assistance or broader project planning with full turnkey responsibility, you can rely on the strength of Flowserve Engineered Services to deliver professional, reliable results.



**Low Frequency Pressure Pulsations**

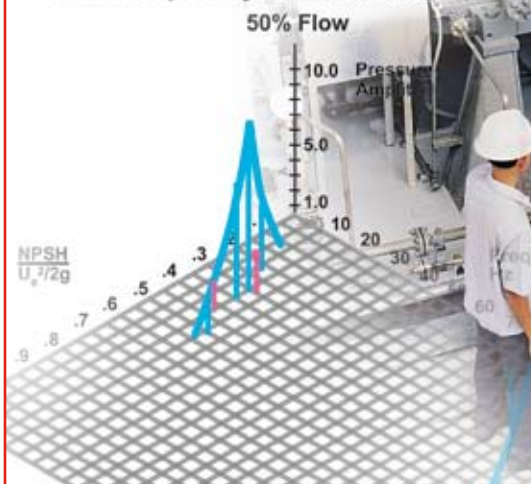

**Flowserve... Supporting Our Customers  
With The World's Leading  
Pump Brands**



**Pumps**

*Your local Flowserve representative:*



**No.19, Block - 1, SIDCO Electronics Complex,  
Guindy, Chennai - 600032**

**Name : S.Manoharan**

**Mobile : 94444 10273**

**Phone : 044 22501480**

**Email : smanoharan@flowtech.in / chennai@flowtech.in**

Printed in U.S.A.  
May 2008  
© Flowserve Corporation